

## OLEDWorks OLED Panel Brite Amber Marker Light

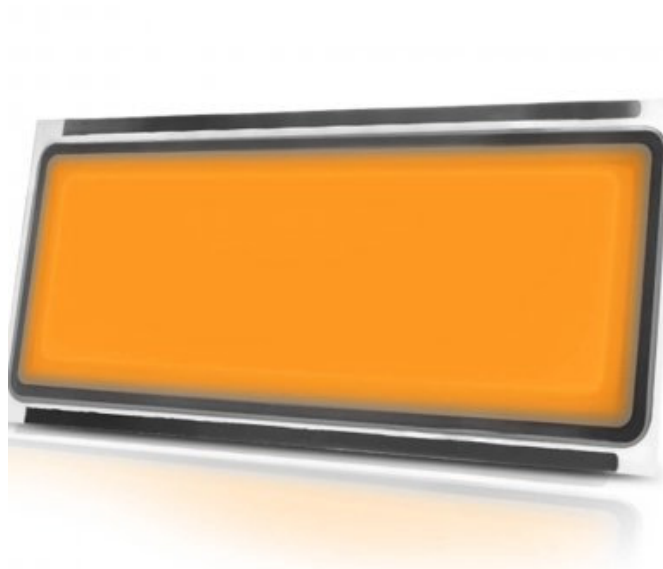

### Thin and healthy OLED-light

When it comes to lighting OLEDs inspire on a whole different level. There is the unique quality of the light itself. In combination with other characteristics e.g. the razor-thin shape and the instant glare-free light when switched on, OLEDs can be used to realize innovative applications and designs.

Amber lighting, free of blue wavelengths, is compatible with natural sleep patterns which are disrupted by blue light. Consequently, amber has increased interest in health care, senior living centers, public facilities such as prisons, and sleeping areas in residences.

The OLEDWorks amber product, at >50 lumens/watt, is an efficient solution that provides a beautiful light quality with an impressive brightness range from marker light applications to task light functions.

### Product features

- Efficacy of more than 50 lm/W
- Free of blue wavelength
- High brightness
- Low thickness of 3.2 mm

### Benefits

- Brightest amber OLED panel commercially available
- Ideal for applications where blue light is undesirable
- All the known advantages of OLED technology: – thin – homogenous – instant glare free

### Applications

Every OLED light-application that is commercially viable and easy to implement. Special light-application for interior spaces that require beautiful and high performance amber lighting

## Description

The OLED Panel Brite Amber Marker Light is a flat light source. Focusing on general lighting applications, OLEDWorks OLED Lighting is developing products with a high lumen output at low costs. One further significant step in this direction is the range extension of the OLEDWorks OLED Panel Brite Amber Marker Light.

## Introduction

OLED is a large-area diffuse light source. Unlike incandescent bulbs, which generate light by passing electricity through a wire, or fluorescent lamps, which pass current through a gas, OLED lighting works by passing electricity through one or more extremely thin layers of organic semiconductor material. These layers are sandwiched between one positively and one negatively charged electrode. The 'sandwich' is placed on a sheet of glass or other transparent material known as the substrate. The OLED is protected by a metal encapsulation and a flat heat spreader on the rear side. When current is applied to the electrodes, they inject positively and negatively charged holes and electrons. These recombine in the organic layer of the sandwich and create a brief, high-energy state called 'exciton'. As this layer returns to its original stable, non-excited state, the energy flows evenly through the organic film causing it to emit light.

## This document refers to

Product	Integration Level	Product Code
OLED Panel Brite Amber Marker Light	2	LPA1015RIAML201



## Standard compliance and sustainability

OLEDWorks products are environmentally friendly and provide efficient illumination without the use of hazardous materials.

This product is compliant with UL8752. This product is UL recognized in file E364056 Vol. I



Within the UL report certain 'Conditions of Acceptability' are mentioned as follows. When installed in the end product, the following shall be taken into consideration:

1. These products have been evaluated for connection to an isolated DC Class 2 constant current power source.
2. This product has been evaluated for use in dry or damp locations.
3. The OLED panel temperature shall not exceed 80 °C.
4. Input leads to the OLEDs are intended for factory installation only. Strain relief to be considered in the end-use application if leads are subjected to mechanical stress.
5. Input leads to the OLED panels shall be sufficiently separated from higher voltage conductors in the end-product in compliance with end-product requirements.

## System

	Description	Remark
Indoor / outdoor	Indoor buildings	location with insignificant shock and vibration
Ingress protection		not applicable for OLED components
OLED color	Amber	
Carrier material	Glass	
Cable	AWG 26	
RoHS conform	Yes	2011/65/EU

## Operational environmental conditions\*

Specification item	Value	Unit	Condition
Ambient temperature	+5 ... +40	°C	
Relative humidity	20 ... 80	%rH	no dew, no water spray, a maximum %rH of 60 is recommended.
Recommended internal operation temperature (OLED organic temperature)	≤ 30	°C	local temperature
Maximum internal operation temperature (OLED organic temperature)	≤ 80	°C	local temperature, for T > 30 °C lifetime will be reduced.

\* please refer to Thermal Characteristics on page 20 for more information.

The Brite Amber is designed for indoor use only. Do not expose to water or excessive moisture.

## Storage conditions\*<sup>1</sup>

Specification item	Value	Unit	Condition
Ambient temperature	-20 ... +60	°C	
Relative humidity	5 ... 85	%rH	no dew, no water spray

\*<sup>1</sup> Recommended storage temperature is between 15 ... 25 °C with a humidity < 65 %rH.

## Transport conditions

Specification item	Value	Unit	Condition
Ambient temperature	-20 ... +60	°C	
Relative humidity	5 ... 85	%rH	no dew, no water spray

## MECHANICAL DIMENSIONS

Specification item	Value	Unit	Condition
Brite Amber marker light	length	101.6 ± 0.1	mm
	width	41.0 ± 0.1	mm
	height	3.2 ± 0.15	mm
	weight	12.7 ± 0.2	gram
Cable	total length	203.0 ± 5	mm
	length outside panel	183.68 ± 5	mm
	diameter	1.4 ± 0.2	mm
Light emitting area	length	88.0 ± 0.1	mm
	width	25.0 ± 0.1	mm
	area	22	cm <sup>2</sup>

## Diagrams of the Brite Amber Marker Light

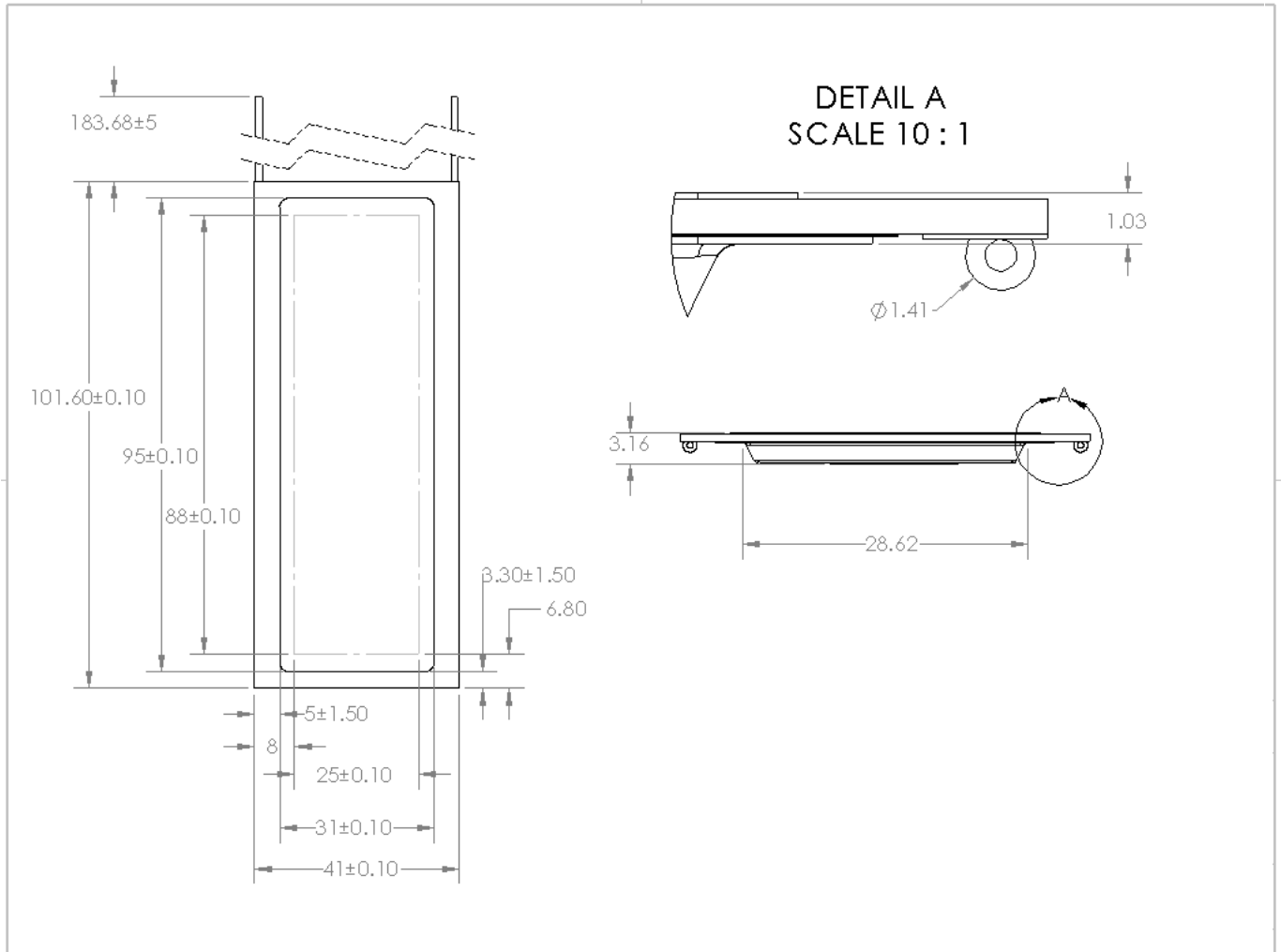

Figure 1: Brite Amber – front and side view

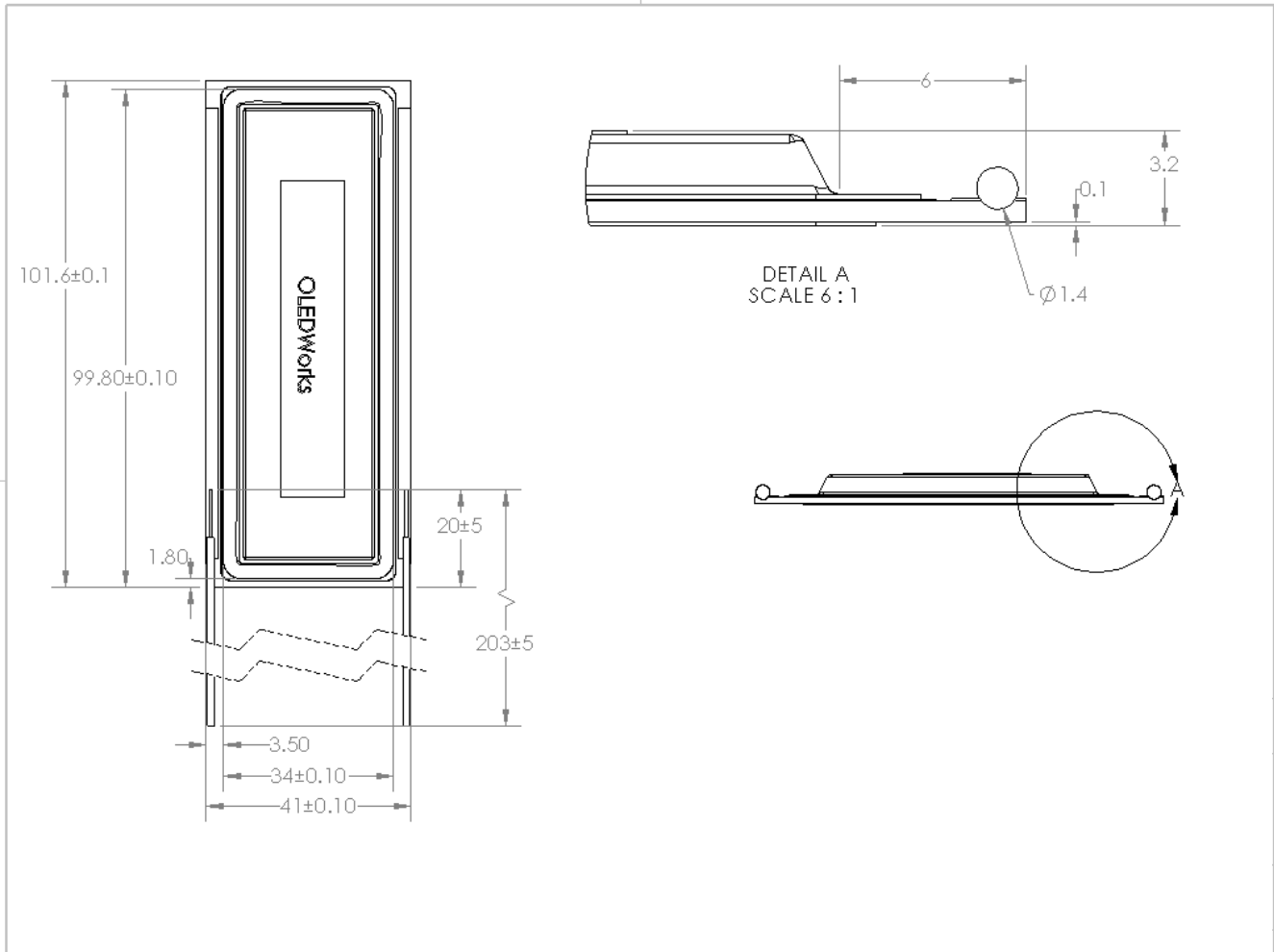

Figure 2: Brite Amber – rear and side view

## Mechanical handling

OLEDs are electronic components and should not be tampered with in any way. They are made of thin glass with potentially sharp edges. Avoid mechanical stress, such as shock, pressure, bending, torsion and especially point loads on the OLED. To avoid fingerprints on the front side, preferably handle the OLED from the sides. Gloves or finger cots are recommended at all times whilst handling the OLED.

Avoid contact with water. Do not submerge OLEDs in any kind of solvent, acid, base, salt or other chemicals.

In case of damage to the product, disconnect the product from power supply without touching the damaged parts. Do not reconnect the product. Contact the manufacturer or a qualified service technician.

Improper use can cause OLEDs to break resulting in glass splinters. Please handle all OLEDs with care to avoid breakage as especially the edges of the OLED are very delicate. Use of protective gloves is advised, in particular with broken OLEDs or OLEDs with sharp edges/corners. Avoid direct contact with broken OLEDs.

The product may become warm during normal use. Do not cover with materials that are flammable.



Do not bend



Do not twist



Do not press

## ELECTRICAL AND OPTICAL CHARACTERISTICS - OLED

### Electrical characteristics

Specification item	Value	Unit	Condition
OLED rated current, $I_{in \text{ rated}}$	0.044	A	
OLED voltage at $t=0$ , $U_{in}$	6.1 +/- 0.4	V DC	$I_{in \text{ rated}}$
OLED voltage at end of life, $U_{EOL} = U_{in \text{ max}}$	6.82	V DC	$I_{in \text{ rated}}$
Power consumption at $t=0$ , $P_{in}$	0.27	W	$I_{in \text{ rated}}$
Power consumption at end of life, $P_{EOL} = P_{in \text{ max}}$	0.3	W	$I_{in \text{ rated}}$

All data nominal at stabilized conditions after 5 min warm-up,  $T_{\text{organic}} = 30 \text{ }^{\circ}\text{C}$ .

### OLED connection

The OLED Panel Brite Amber Marker Light is providing a connection for the plus and minus input via a 26 AWG wire in approximately 200mm length. Use of power supplies with dedicated controls for turning off output power if an OLED fails is preferred when operating the OLED Panel Brite Amber Marker Light. Please ensure the driver you choose is able to provide the needed current output for the Brite Amber Marker Light. For more details on suiting driver solutions please contact OLEDWorks.

### Dimming

Both pulse width modulation (PWM) and amplitude modulation (AM) techniques can be used to dim the OLED. More detailed information can be found in the design-in guide for the Brite Amber Marker Light.

### OLED voltage

The voltage of the OLED is very consistent throughout operation, temperature of the organics and the age of the OLED.

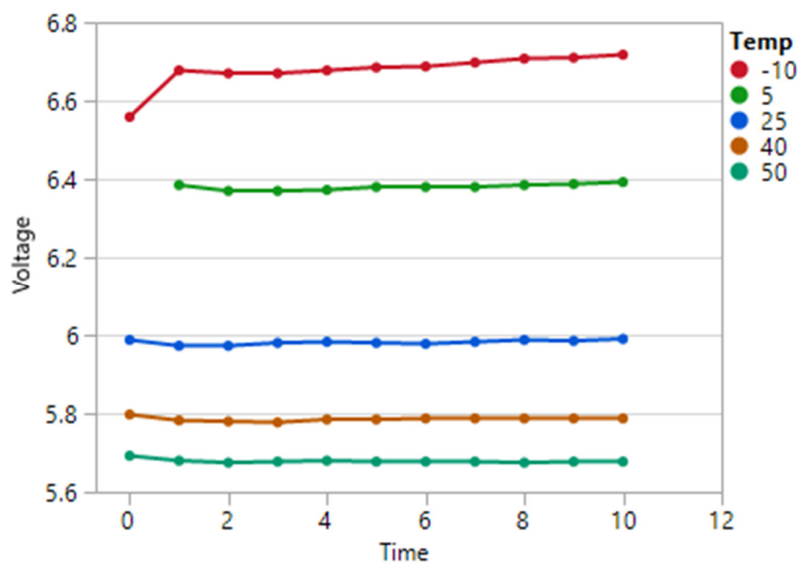

Figure 3: typical voltage at temperature of the Brite Amber at different driving currents



## Optical characteristics Brite Amber Marker Light\*2

Specification item	Value	Unit	Condition
Luminance, nominal	2000	cd/m <sup>2</sup>	@ I <sub>in rated</sub> = 0.044 A, perpendicular, center
Luminous flux	15 ± 10 %	lm	@ I <sub>in rated</sub> = 0.044 A with L70B50 >25khrs
Luminous efficacy, nominal	50	lm/W	@ I <sub>in rated</sub> = 0.044 A
Color	Amber		
Chromaticity x, nominal	0.429		integral measurement, CIE 1931
Chromaticity y, nominal	0.562		
Chromaticity u', nominal	0.3200		integral measurement, CIE 1976
Chromaticity v', nominal	0.5497		
Color spec limits CIE xy	0.5570 0.4342 0.570 0.4253		corner coordinates of area in colorspace
Color spec limits CIE u'v'	0.3140 0.5507 0.3274 0.5497		corner coordinates of area in colorspace
CCT	1867	K	@ I <sub>in rated</sub> = 0.044 A
Homogeneity	≥ 80%		6 point measurement, min/max, I <sub>in rated</sub> = 0.044 A

\*2 all data for stabilized electrical conditions of the device after 5 min warm-up period, integration level 1.

## OLED spectrum

Typical spectra of the OLED at different driving currents are given in Figure 4.

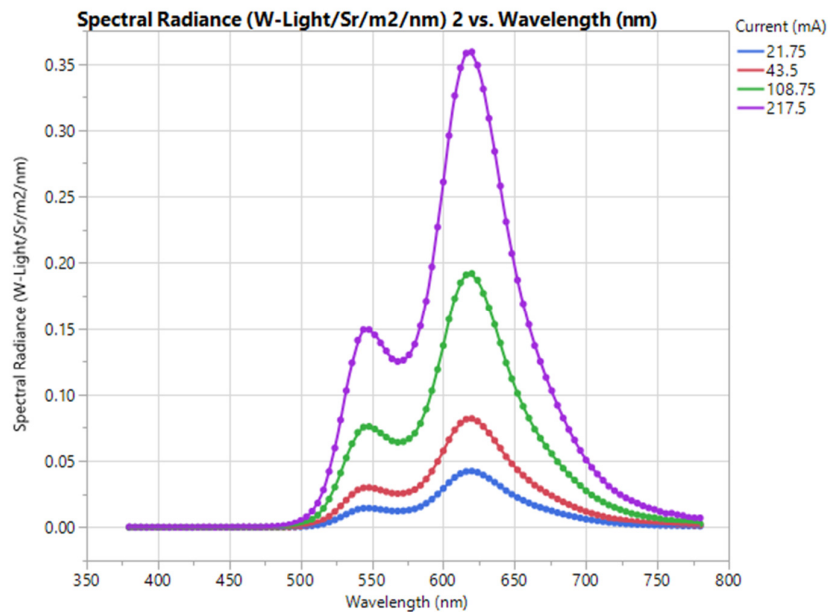

Figure 4: typical emission spectra of the Brite Amber at different driving currents

### Current – voltage – luminance characteristics

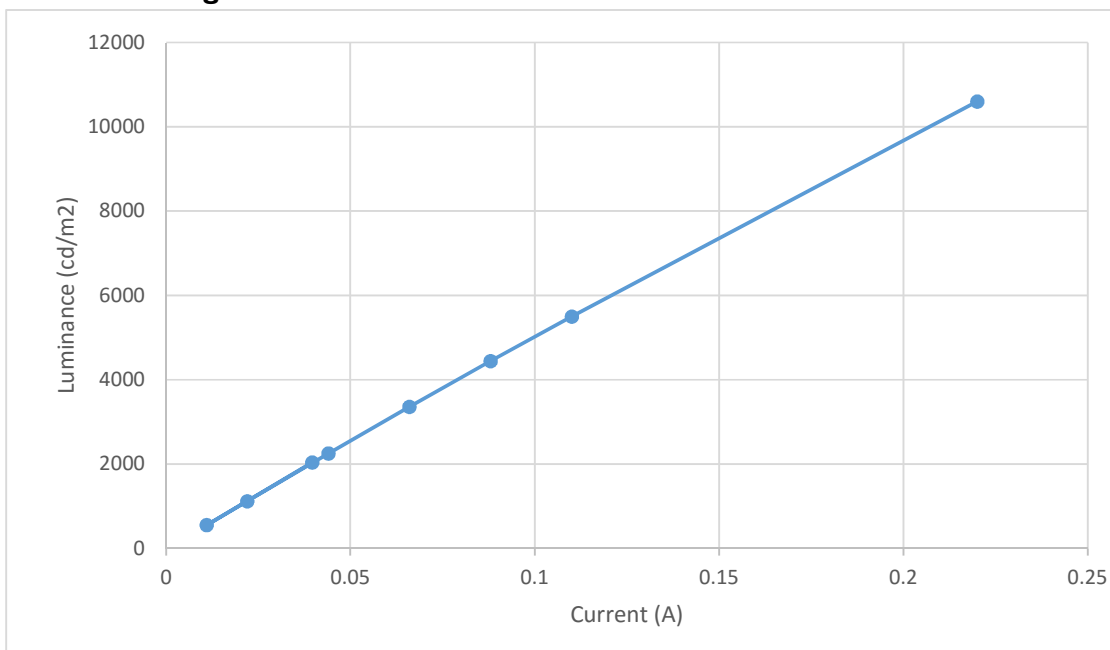

Figure 5: Luminance versus forward current at room temperature

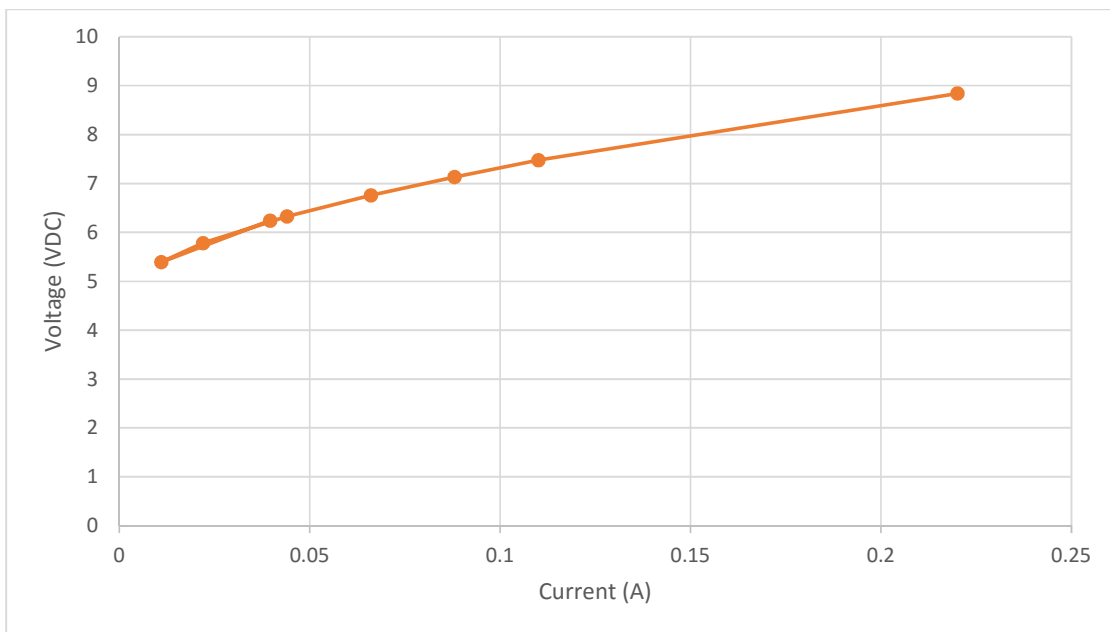

Figure 6: Voltage versus forward current at room temperature

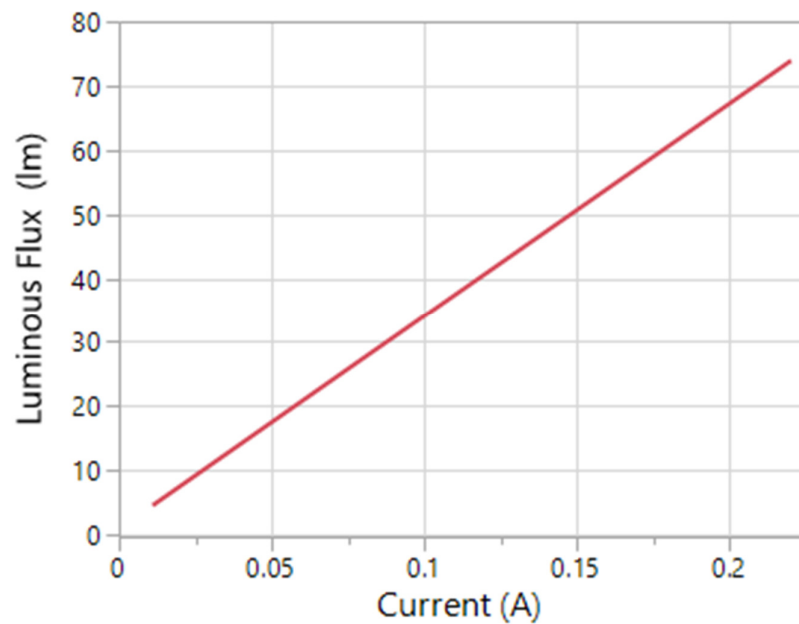

Figure 7: Luminous flux vs current

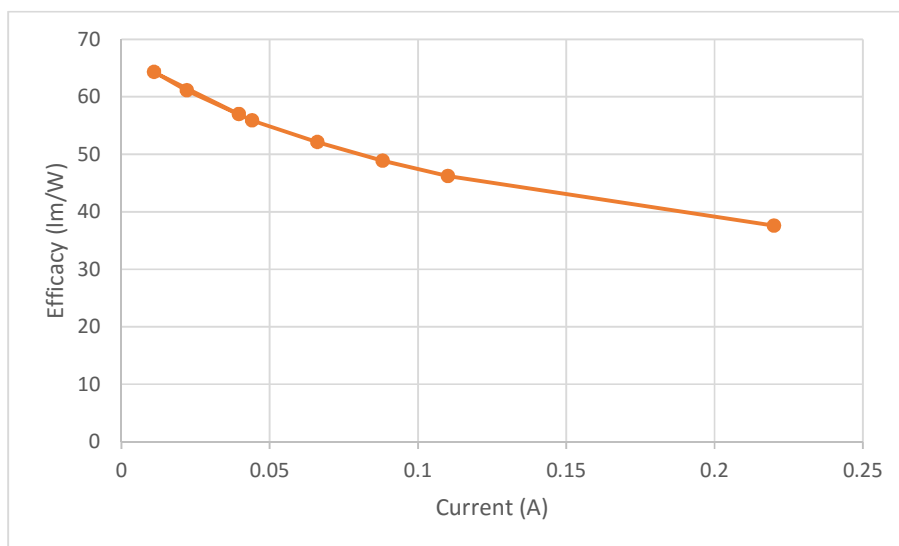

Figure 8: Efficacy versus current at room temperature

## Angular dependency

The luminance (measured in  $\text{cd}/\text{m}^2$ ) of the OLED light depends on angle of observation. Figure 9 shows typical values for the OLED Panel Brite Amber Marker light I operated at different driving currents.

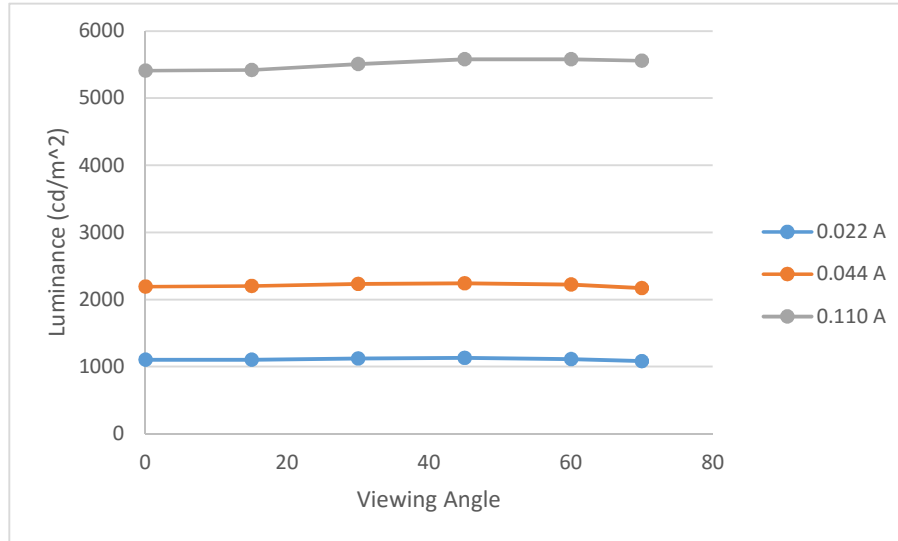

Figure 9: Luminance as function of the viewing angle. Driving currents  $I = 0.022 \text{ A}$ ,  $0.044 \text{ A}$ ,  $0.110 \text{ A}$

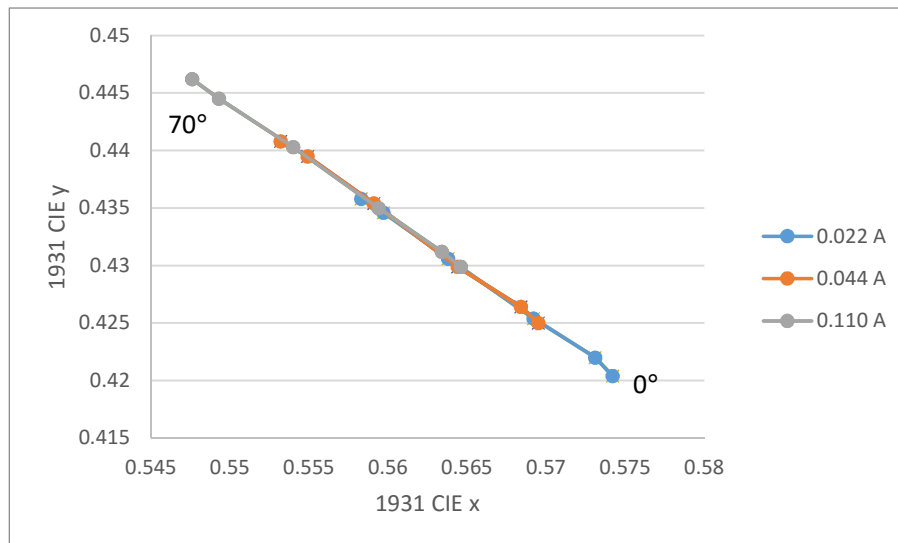

Figure 10: CIE  $x/y$  as function of the viewing angle. Driving currents  $I = 0.022 \text{ A}$ ,  $0.044 \text{ A}$ ,  $0.110 \text{ A}$

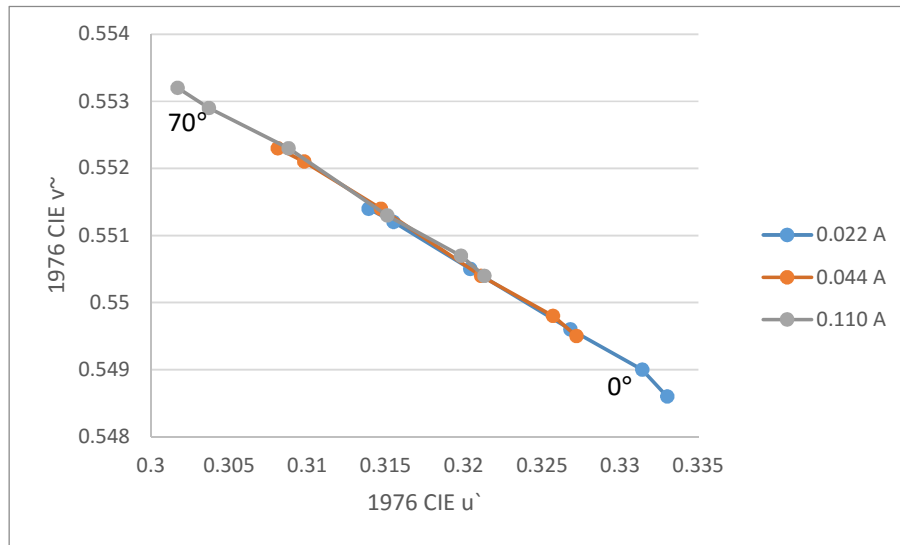

Figure 11: CIE  $u'/v'$  as function of the viewing angle. Driving currents  $I = 0.022\text{ A}, 0.044\text{ A}, 0.110\text{ A}$

## THERMAL CHARACTERISTICS

OLEDs can generate a certain amount of heat. Despite the fact that no active cooling is required, the panels should not be covered in order to avoid heat accumulation.

The OLED temperature during operation depends on ambient conditions and driving current. Indicative values for internal (organics) temperature of the device can be measured at the glass surface at the center of the device with a thermocouple attached.

Typical temperature for the Brite Amber Marker Light is 30 °C with the following set-up:

- $I = I_{\text{in rated}} = 0.044\text{ A}$
- $T_{\text{ambient}} = RT = 25\text{ °C}$
- vertical orientation
- climate chamber, no active convection.

## Lifetime

Luminous flux reduces with lifetime of the OLED. The luminous flux of the Brite Amber Marker Light decreases to approximately 70% after 25,000 hours at rated current.

### Brite Amber Marker Light

Specification item	Value	Brightness	Condition
OLED Panel Lifetime L70B50	25,000 hours	2,000 cd/m <sup>2</sup>	@ I <sub>in rated</sub> = 0.044 A, T <sub>organic</sub> = 30 °C

Voltage increases over lifetime of the OLED; color and homogeneity of the panel may also change.

### Storage lifetime

Under the recommended storage conditions the shelf life of the OLED is 2 years.

## General handling recommendations and care

### Cleaning

Please avoid scratching the front side with any hard or sharp objects. OLEDs can be cleaned with any soft textile. If required use a damp cloth but avoid extensive moisture.

Use of a compressed air spray to remove regular dust from the individual panels is advised for everyday cleaning. Should fingerprints or more persistent contamination occur, isopropanol applied to a lint-free cloth can be used to gently clean the surface of the OLED. Clean using circular movements beginning at the center of the OLED and moving outwards towards the edges. Contact with water is to be avoided.

### Storage and operating

Please note that the recommended storage temperature is 15 °C to 25 °C. The recommended relative storage humidity is 65% or lower. Avoid exposing OLEDs to UV light.

### Safety

Please be careful when handling OLEDs. The edges of the OLED panels may be sharp and can chip or break.

In the unlikely event that an OLED fails, the temperature may rise locally to high levels. To avoid this the OLED should be turned off immediately.

### Disposal

OLEDs should be disposed of according to local legislation

## Logistical data

Specification item	Value
Product name	OLED Panel Brite Amber Marker Light
Order code	LPA1015RIAML201
Pieces per box	10

## Contact:

OLEDWorks LLC  
1645 Lyell Avenue, Suite 140  
Rochester, NY 14606, USA

OLEDWorks GmbH  
Philipsstr. 8, 52068 Aachen, Germany

[OWinfo@oledworks.com](mailto:OWinfo@oledworks.com)

For more information visit:  
[www.oledworks.com](http://www.oledworks.com)  
[www.facebook.com/oledworks](https://www.facebook.com/oledworks)  
[www.twitter.com/oledworks](https://www.twitter.com/oledworks)

© 2017 OLEDWorks LLC  
All rights reserved. Correct as of May 2017.