

OLEDWorks Lumiblade OLED Panel Brite 3 Square

Neutral white – 4000K

Warm white – 3000K



OLED technology offers unique designs in lighting applications.

When it comes to lighting, OLED inspires on a whole different level. The quality of the light itself in combination with its unique design characteristics, OLED lighting can be used to realize innovative applications and designs.

The third generation of the Brite family brings OLED further into functional lighting applications. With the luminous flux of up to 300 lumens, the Brite products are the brightest white OLED panel commercially available worldwide.

The rigid OLED panels are available in three shapes, rectangle, round, and square, and two color temperatures, 3000K and 4000K, making it easy to bring lighting into spaces and products that require high-function and beautiful illumination.

OLED is a human-centric light source.

Lighting affects our well-being in many ways, from physiological impact to emotional response. OLED lighting delivers a positive experience for our health in multiple ways.

OLED light contains longer wavelengths of blue which are safer for our eyes than the high blue peaks found in LED lighting. It delivers the same amount of light as LED, in superior quality, with significantly less hazardous blue light.

Validated through the IEC standard for physiological risk of blue and infrared light – our OLEDs have no risk for skin and eyes and are rated as exempt for all photobiological risks.

OLED light is a naturally diffuse light source.

OLED provides soft, yet bright full spectrum illumination resulting in artificial light that resembles daylight. It emits light from the entire surface area, rather than from one or multiple points. This presents a soft brightness and glare-free experience making it an ideal solution for comforting light able to be placed close to the user. Studies have shown that OLED lighting, in comparison to LED standards, also resulted in lower eye fatigue.

Standard Compliance and Sustainability

OLEDWorks products are environmentally friendly and provide efficient illumination without the use of hazardous materials.

This product is RoHS (EU Directive 2011/65/EU) and IEC 62868 (OLED safety) and IEC 62922 (OLED performance) compliant.



This product is compliant with UL8752 (OLED safety). This product is UL recognized in file E353273.



Within the UL report certain 'Conditions of Acceptability' are mentioned as follows. When installed in the end product, the following shall be taken into consideration:

1. These products have been evaluated for connection to an isolated DC Class 2 constant current power source.
Caution: Do not operate the OLED panel with other than UL-Class 2 power supplies.
2. This product has been evaluated for use in dry or damp locations.
3. The OLED panel temperature shall not exceed 80 °C.
4. Input leads to the OLEDs are intended for factory installation only. Strain relief to be considered in the end-use application if leads are subjected to mechanical stress.
5. Input leads to the OLED panels shall be sufficiently separated from higher voltage conductors in the end-product in compliance with end-product requirements.

System

	Description	Remark
Indoor / outdoor	Indoor buildings	location with insignificant shock and vibration
Ingress protection		not applicable for OLED components
Classification	Applicable in applications with Class III (IEC) and Class II (UL) protection	Application standard IEC61140
OLED color	White	
Carrier material	Glass	
Cable	AWG 26	Brite 3 Square 4000K Level 1.5
Connector	5-pin Molex Picoblade 510210500	Brite 3 Square 4000K Level 2 Brite 3 Square 3000K Level 1.5 Brite 3 Square 3000K Level 2
RoHS conform	Yes	2011/65/EU

Operational Environmental Conditions*

Specification item	Value	Unit	Condition
Ambient temperature	+5 ... +40	°C	
Relative humidity	20 ... 80	%rH	no dew, no water spray, a maximum %rH of 60 is recommended.
Recommended internal operation temperature (OLED organic temperature)	≤ 35	°C	local temperature
Maximum internal operation temperature (OLED organic temperature)	≤ 80	°C	local temperature, for T > 40 °C lifetime will be reduced.

* please refer to Thermal Characteristics on page 26 for more information.

The Brite 3 Square is designed for indoor use only. Do not expose to water or excessive moisture.

Storage Conditions*¹

Specification item	Value	Unit	Condition
Ambient temperature	-40 ... +60	°C	
Relative humidity	5 ... 85	%rH	no dew, no water spray

*¹ Recommended storage temperature is between 15 ... 25 °C with a humidity < 65 %rH.

Transport Conditions

Specification item	Value	Unit	Condition
Ambient temperature	-40 ... +60	°C	
Relative humidity	5 ... 85	%rH	no dew, no water spray

MECHANICAL DIMENSIONS

Specification item		Value	Unit	Condition
Brite 3 Square 4000K Level 1 Brite 3 Square 4000K Level 1.5 Brite 3 Square 3000K Level 1 Brite 3 Square 3000K Level 1.5	length	120.5 ± 0.2	mm	
	width	120.5 ± 0.2	mm	
	height	1.4 ± 0.15	mm	
	weight	38 ± 1	gram	
Brite 3 Square 4000K Level 2 Brite 3 Square 3000K Level 2	length	127 ± 0.2	mm	dimensions excluding cable
	width	127 ± 0.2	mm	
	height	2.1 ± 0.2	mm	excluding Molex Picoblade plug
	diameter screw opening	3.2	mm	for fixation with M3 screws
	distance screw openings	127 ± 0.2	mm	
	weight	70 ± 1	gram	
Light emitting area	length	102.2 ± 0.3	mm	Brite 3 Square 4000K Level 1 Brite 3 Square 4000K Level 1.5 Brite 3 Square 4000K Level 2 Brite 3 Square 3000K Level 1 Brite 3 Square 3000K Level 1.5 Brite 3 Square 3000K Level 2
	width	102.2 ± 0.3	mm	
	area	104.5	cm ²	

Diagrams of Brite 3 Square Level I

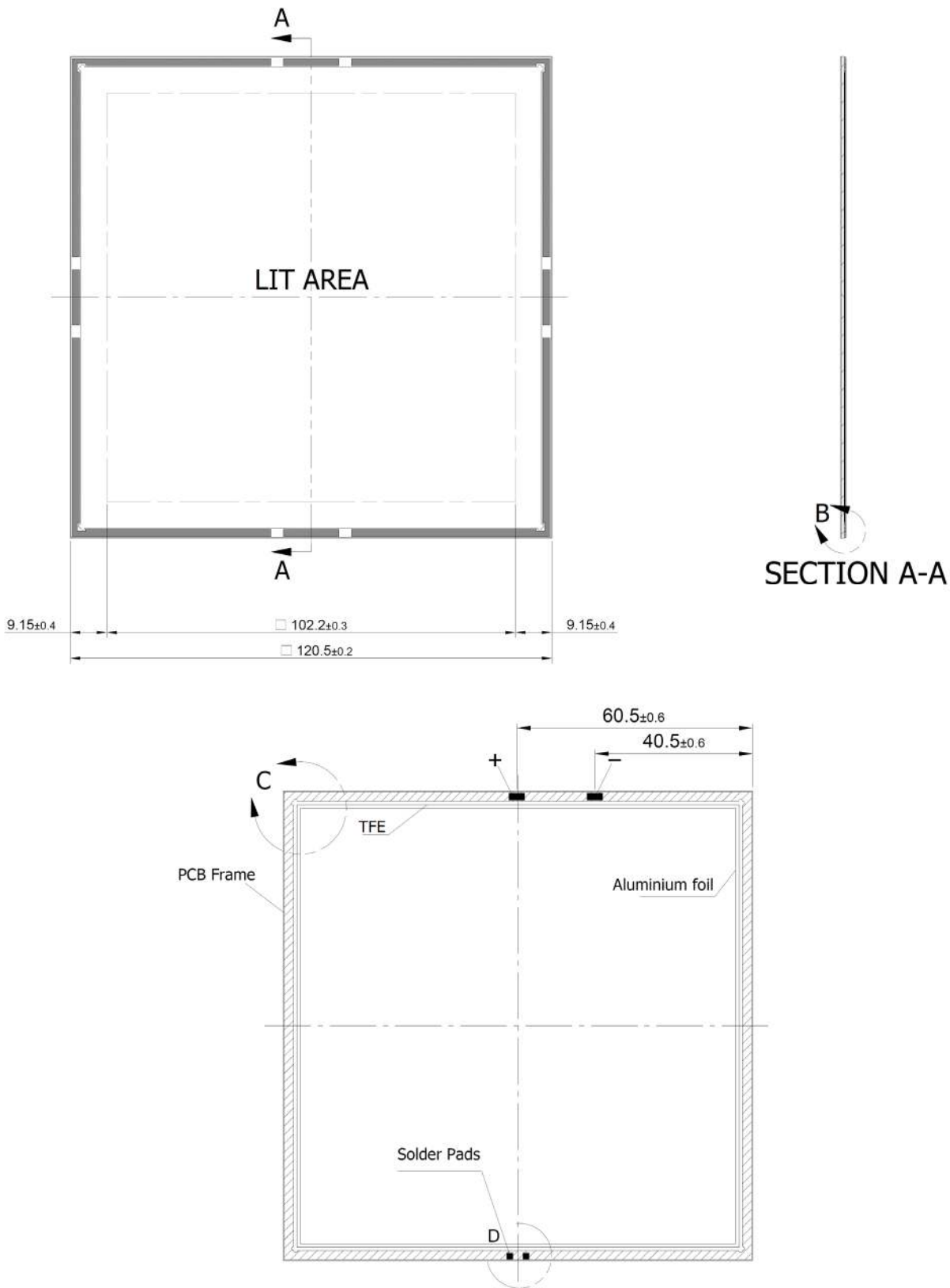


Figure 1: Brite 3 Square Level I – front and side view (top), rear view (bottom)

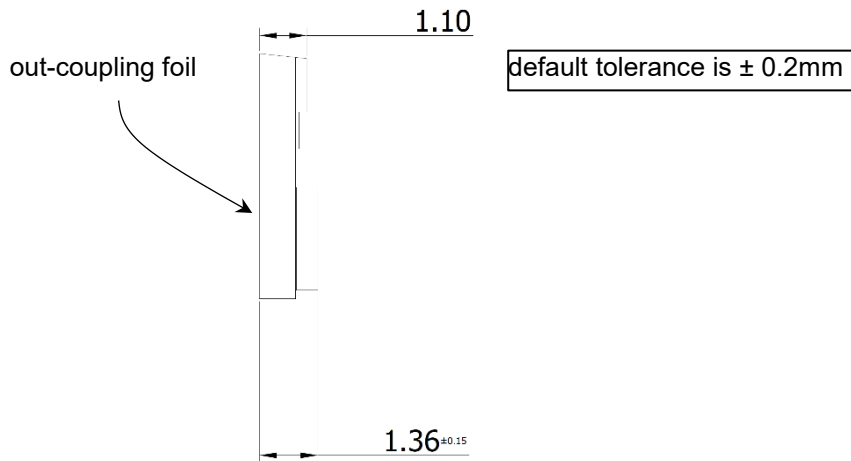


Figure 2: Detail B of Figure 1; Brite 3 Square Level 1

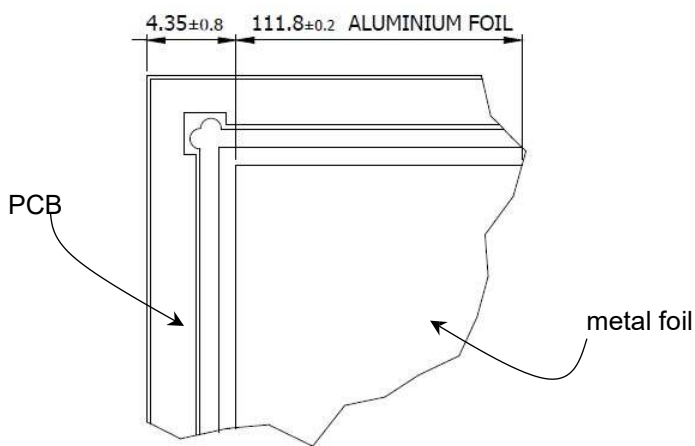


Figure 3: Detail C of Figure 1 – corner of PCB frame - Level 1

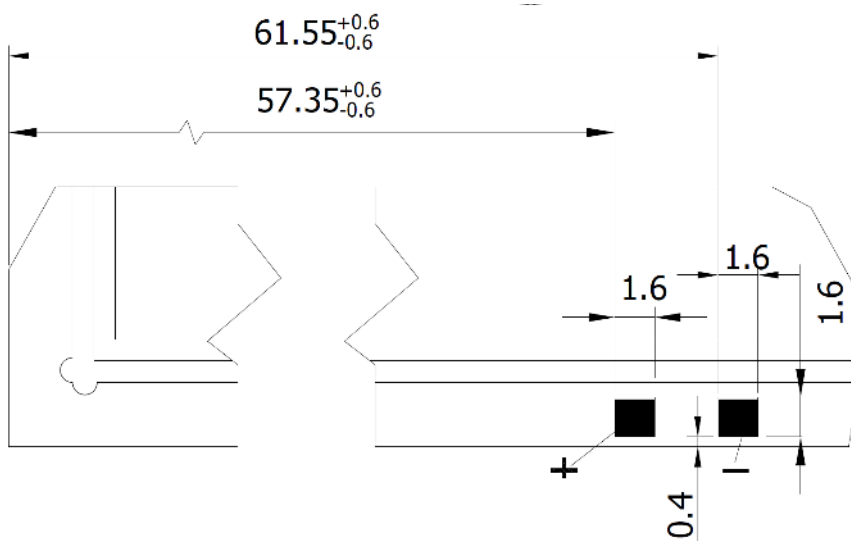


Figure 4: Detail D of Figure 1 – contact pads and distance to corner - Level 1

Diagrams of Brite 3 Square Level 1.5

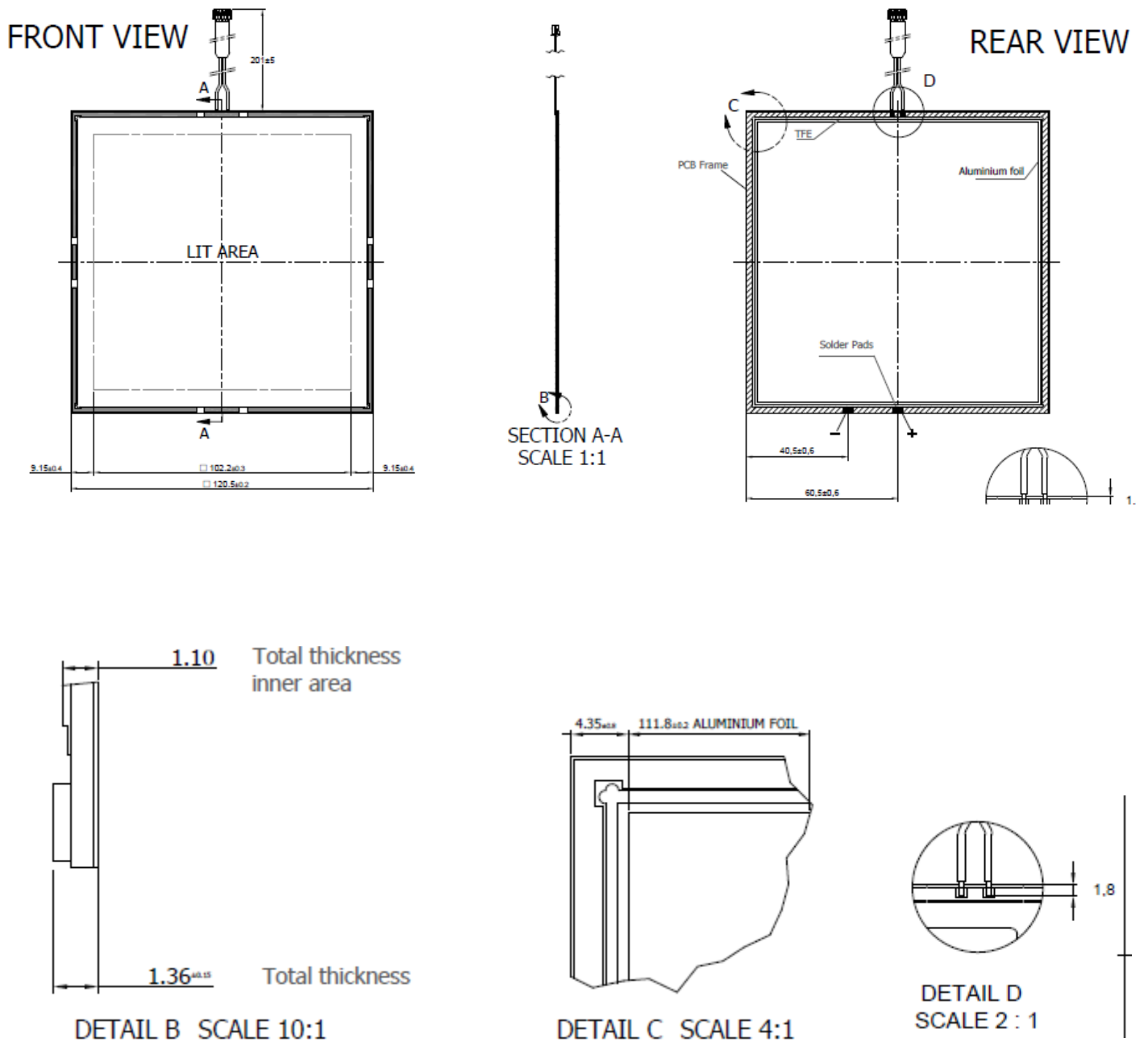


Figure 5: Brite 3 Square Level 1.5 – front, rear and side view (top), details (bottom)

Diagrams of Brite 3 Square Level 2

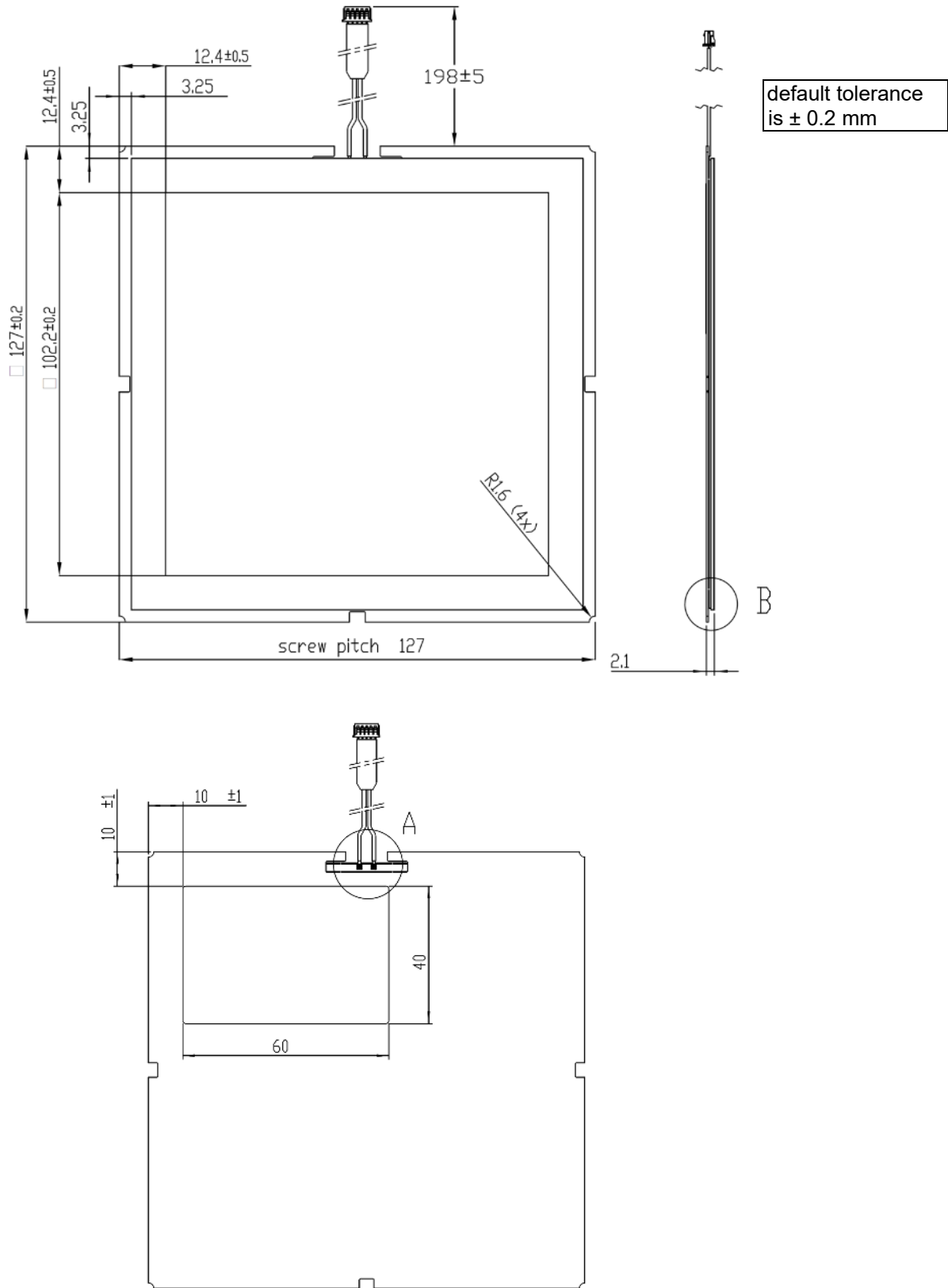


Figure 6: Brite 3 Square Level 2 – front and side view (top), rear view (bottom)

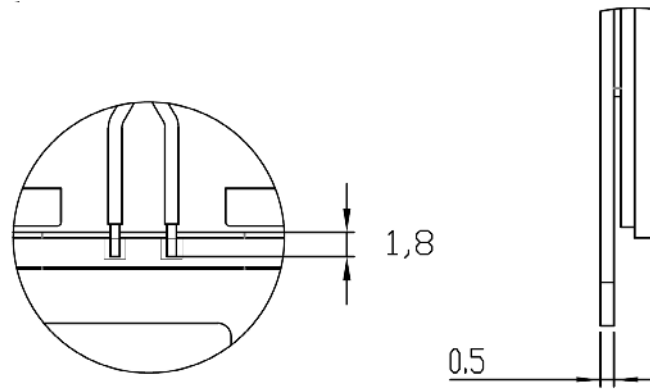


Figure 7: Details A and B of Figure 6 – solder orientation on PCB and thickness of metal back plate - Level 2

Mechanical Handling

OLEDs are electronic components and should not be tampered with in any way. They are made of thin glass with potentially sharp edges. Avoid mechanical stress, such as shock, pressure, bending, torsion and especially point loads on the OLED. To avoid fingerprints on the front side, preferably handle the OLED from the sides. Gloves or finger cots are recommended at all times whilst handling the OLED.

Avoid contact with water. Do not submerge OLEDs in any kind of solvent, acid, base, salt or other chemicals.

In case of damage to the product, disconnect the product from power supply without touching the damaged parts. Do not reconnect the product. Contact the manufacturer or a qualified service technician.

Improper use can cause OLEDs to break resulting in glass splinters. Please handle all OLEDs with care to avoid breakage as especially the edges of the OLED are very delicate. Use of protective gloves is advised, in particular with broken OLEDs or OLEDs with sharp edges/corners. Avoid direct contact with broken OLEDs.

The product may become warm during normal use. Do not cover with materials that are flammable.



Do not bend



Do not twist



Do not press

ELECTRICAL AND OPTICAL CHARACTERISTICS

Electrical Characteristics

Specification item	Value	Unit	Condition
OLED rated current, $I_{in \text{ rated}}$	0.215	A	
OLED voltage at $t=0$, U_{in} , Brite 3 Square 4000K	19.6 +/- 1.0	V DC	$I_{in \text{ rated}}$
OLED voltage at $t=0$, U_{in} , Brite 3 Square 3000K	18.7 +/- 1.0	V DC	$I_{in \text{ rated}}$
OLED voltage at end of life, $U_{EOL} = U_{in \text{ max}}$	22	V DC	$I_{in \text{ rated}}$
Power consumption at $t=0$, P_{in} , Brite 3 Square 4000K	4.2	W	$I_{in \text{ rated}}$
Power consumption at $t=0$, P_{in} , Brite 3 Square 3000K	4.0	W	$I_{in \text{ rated}}$
Power consumption at end of life, $P_{EOL} = P_{in \text{ max}}$	4.7	W	$I_{in \text{ rated}}$

All data nominal at stabilized conditions after 5 min warm-up, $T_{organic} = 35 \text{ }^{\circ}\text{C}$.

OLED Drivers

Use of power supplies with dedicated controls for turning off output power if an OLED fails is recommended when operating the OLED Panel Brite 3 Square. Examples of recommended drivers are shown in the table below. These drivers all have sockets compatible with the Molex Picoblade connector 510210500.

Product	Supply voltage	Output channels	Philips Product Code
Driver D230V 80W/0.1-0.5/1A/28V TD/A 8CH	120, 220-240, 277 V AC	8	9254.000.10200
Driver D024V 10W/0.1A-0.4A/28V D/A	24 V DC	1	9254.000.10100
Driver D024V 10W/0.1A-0.4A/28V DMX	24 V DC	1	9254.000.12000

Dimming

Both pulse width modulation (PWM) and amplitude modulation (AM) techniques can be used to dim the OLED. More detailed information can be found in the design-in guide for the Brite 3 Square family.

OLED Connection

The OLED Panel Brite 3 Square is available at three different integration levels. At integration level 1, no cable is attached to the device. Integration levels 1.5 and 2 provide a cable with a Molex Picoblade connector type compatible with the Lumiblade OLED drivers and resistors integrated in the cable which support the recognition of the correct panel settings by the drivers.

At integration level 1 the Brite 3 Square features contact areas on the rear side (see Figure 8). Area A and D provides contact pads A1 or D1 (plus) and A2 or D2 (minus). The individual signals for the 5-wire connector are shown in Figure 9. Only one of the interface areas need to be used for electrical contact.

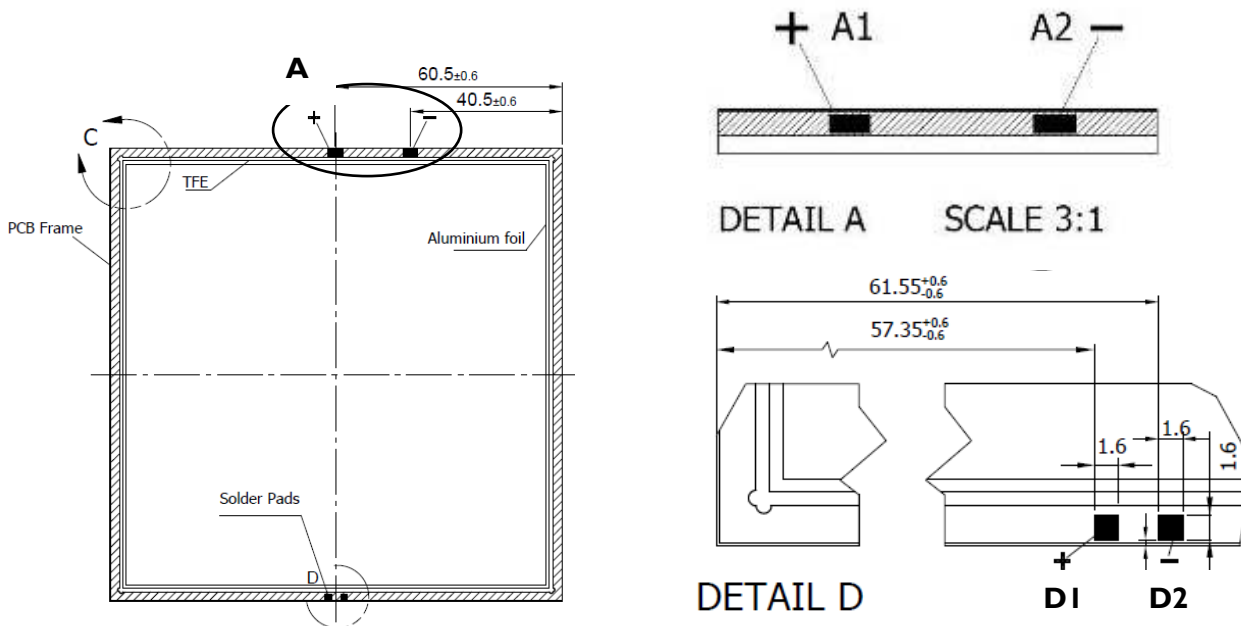


Figure 8: Contact pads of the Brite 3 Square Level 1

The function of the connector is illustrated in Figure 8. A1 and D1 link to the plus pole and A2 and D2 link to the minus pole. Using the Molex connector of the integration level 1.5 and 2 according to the schematic in Figure 9 the dedicated OLED drivers automatically recognize the panel and drive it correctly.

Spin - Molex Picoblade 510210500

Area B

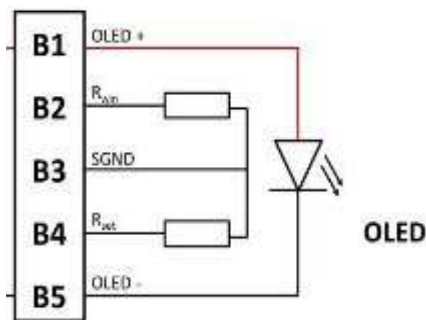


Figure 9: Channel connections from driver to the Brite 3 Square Level 2

Specification item	Value	Unit	Remark
Wire cross-section	26	AWG	flat cable; voltage rating: 300 V; circuits: 5
Wire length	198 ± 5	mm	
Connector (header/crimp)			Molex Picoblade male

OLED Voltage

The voltage of the OLED depends on the point of operation, temperature of the organics and the age of the OLED. As a result, the OLED voltage is affected by the ambient temperature. During operation the temperature of the organics may increase, especially shortly after powering the OLED. At constant current control, this may result in a change in voltage.

Example of voltage evolution after a cold start at different ambient temperature levels is shown in Figure 10. The initial voltage drop is due to the device heating up until steady state (approx. 5 min after turning on). Besides this the voltage/organic temperature depends on the ambient temperature.

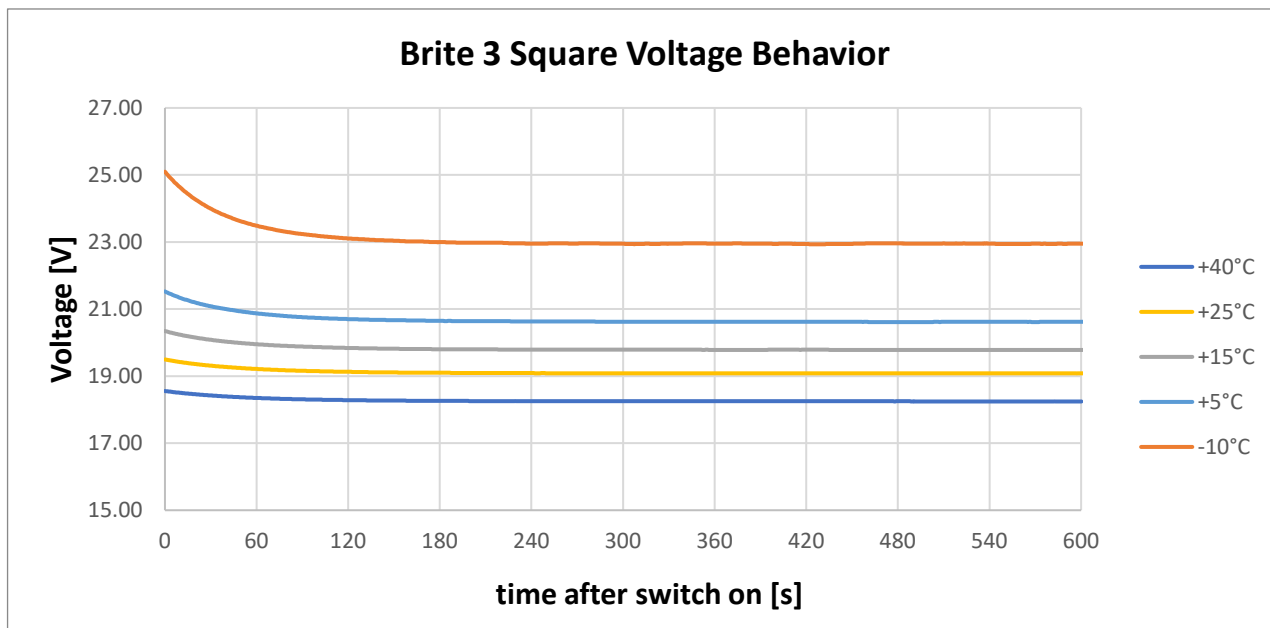


Figure 10: typical voltage evolution after start-up at different ambient temperatures, level 1, vertical orientation, air, $I_{in rated} = 0.215 A$

Short Circuit Behavior

If an OLED fails it can fall into a short circuit. Such a condition may mean that

- no light is generated
- the OLED is heated locally, i.e. one small spot of the OLED surface gets hot
- the current still flows through the OLED but the voltage drops to a lower value.

In case such a fault occurs turning off the OLED is recommended.

No indication based on internal tests or market feedbacks that shorts appear for Brite 3.

Optical Characteristics Brite 3 Square 4000K*2

Specification item	Value	Unit	Condition
Luminance, nominal	7000	cd/m ²	@ $I_{in\ rated} = 0.215\ A$, perpendicular, center
	3000		@ 0.090 A, perpendicular, center
Luminous flux	250 ± 10 %	lm	@ $I_{in\ rated} = 0.215\ A$ with L70B50 = 30khrs
	100 ± 10 %		@ 0.090 A with L70B50 = 100khrs
Luminous efficacy, nominal	57	lm/W	@ $I_{in\ rated} = 0.215\ A$
	61		@ 0.090 A
Color	White		
Chromaticity x, nominal	0.3792		integral measurement, CIE 1931
Chromaticity y, nominal	0.3717		
Chromaticity u', nominal	0.2263		integral measurement, CIE 1976
Chromaticity v', nominal	0.4991		
Duv	-0.0020		center of color box with respect to BBL
Color spec limits CIE xy	0.3704 0.3702 0.3904 0.3832 0.3879 0.3732 0.3679 0.3602		corner coordinates of area in colorspace
Color spec limits CIE u'v'	0.2211 0.4972 0.2291 0.5059 0.2315 0.5011 0.2234 0.4922		corner coordinates of area in colorspace
CCT	4000	K	@ $I_{in\ rated} = 0.215\ A$
Color Rendering Index: CRI / R9	>90 / >75		@ $I_{in\ rated} = 0.215\ A$
TM-30 metrics: R _f / R _g	85 / 97		@ $I_{in\ rated} = 0.215\ A$
Surface uniformity chromaticity	0.0020		Referring to IEC 62922
Angular chromaticity uniformity	0.0050		Referring to IEC 62922
Homogeneity	≥ 90%		9 point measurement, min/max, $I_{in\ rated} = 0.215\ A$

*2 all data for stabilized electrical conditions of the device after 5 min warm-up period, integration level 1.

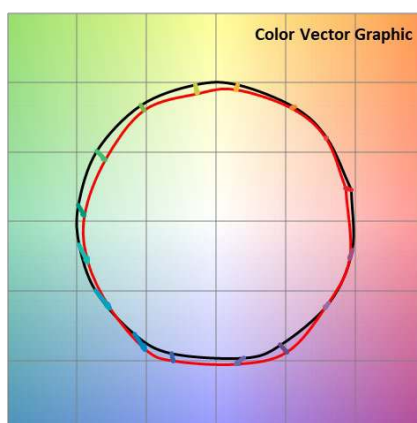


Figure 11: Color vector graphic based on TM-30 metrics for Brite 3 Square 4000K

Optical Characteristics Brite 3 Square 3000K*²

Specification item	Value	Unit	Condition
Luminance, nominal	8500	cd/m ²	@ I _{in rated} = 0.215 A, perpendicular
	3000		@ 0.070 A, perpendicular
Luminous flux	300 ± 10 %	lm	@ I _{in rated} = 0.215 A with L70B50 = 30khrs
	100 ± 10 %		@ 0.070 A with L70B50 = 100khrs
Luminous efficacy, nominal	75	lm/W	@ I _{in rated} = 0.215 A
	85		@ 0.070 A
Color	White		
Chromaticity x, nominal	0.4345		integral measurement, CIE 1931
Chromaticity y, nominal	0.3992		
Chromaticity u', nominal	0.2511		integral measurement, CIE 1976
Chromaticity v', nominal	0.5191		
Duv	-0.0016		center of color box with respect to BBL
Color spec limits CIE xy	0.4270 0.4010		corner coordinates of area in colorspace
	0.4470 0.4073		
	0.4420 0.3973		
	0.4220 0.3910		
Color spec limits CIE u'v'	0.2455 0.5187		corner coordinates of area in colorspace
	0.2557 0.5242		
	0.2568 0.5195		
	0.2465 0.5139		
CCT	3000	K	@ I _{in rated} = 0.215 A
Color Rendering Index: CRI / R9	>90/ >50		@ I _{in rated} = 0.215 A
TM-30 metrics: R _f / R _g	85 / 98		@ I _{in rated} = 0.215 A
Surface chromaticity uniformity	0.0020		Referring to IEC 62922
Angular chromaticity uniformity	0.0050		Referring to IEC 62922
Homogeneity	≥ 90%		9 point measurement, min/max, I _{in rated} = 0.215 A

*² all data for stabilized electrical conditions of the device after 5 min warm-up period, integration level I.

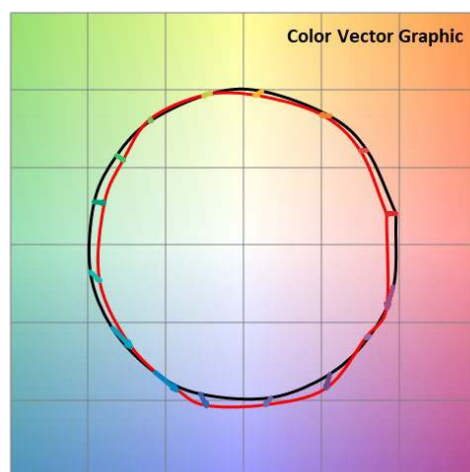


Figure 12: Color vector graphic based on TM-30 metrics for Brite 3 Square 3000K

OLED Spectral Power Distribution (SPD)

Typical spectra of the OLED at different driving currents are given in Figure 13 and 14.

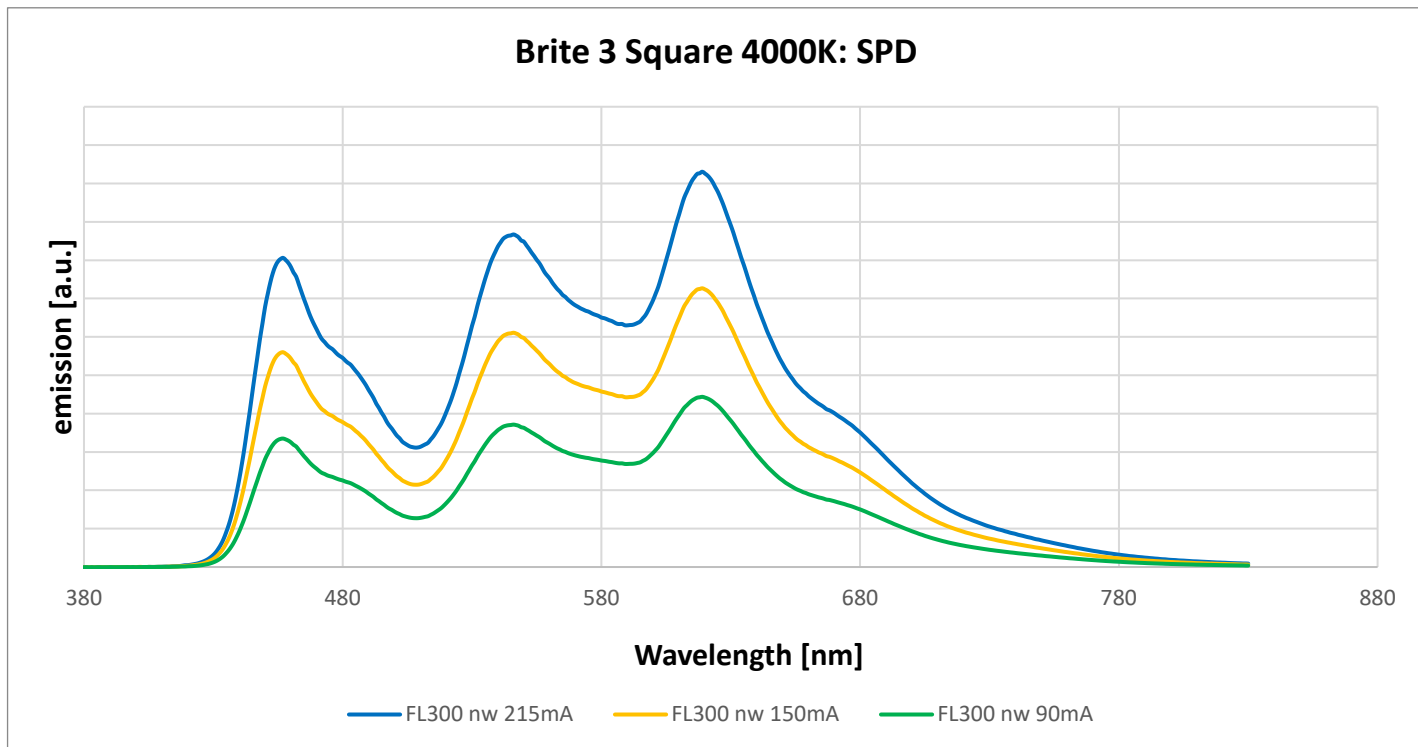


Figure 13: typical emission spectra of the Brite 3 Square 4000K at different driving currents ($I = 0.090\text{ A}, 0.150\text{ A}, 0.215\text{ A}$)

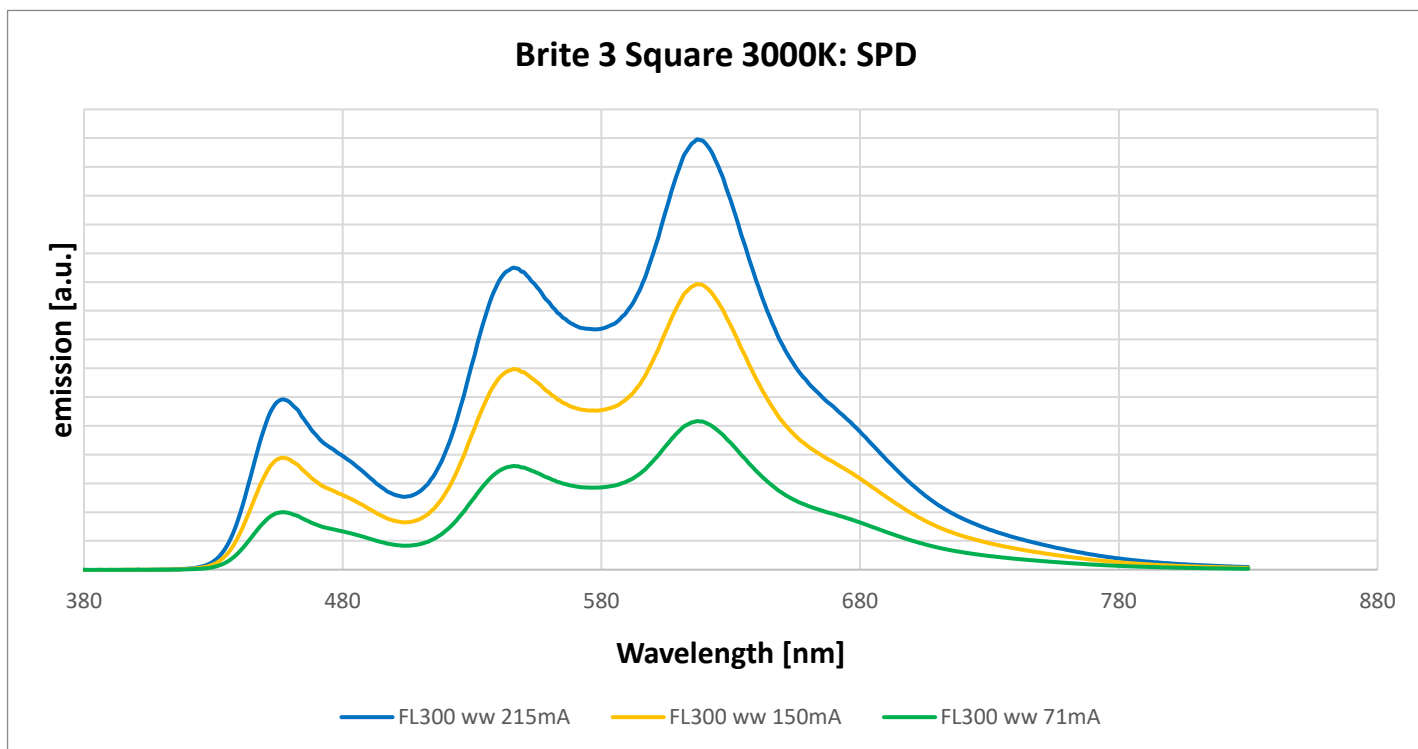


Figure 14: typical emission spectra of the Brite 3 Square 3000K at different driving currents ($I = 0.071\text{ A}, 0.150\text{ A}, 0.215\text{ A}$)

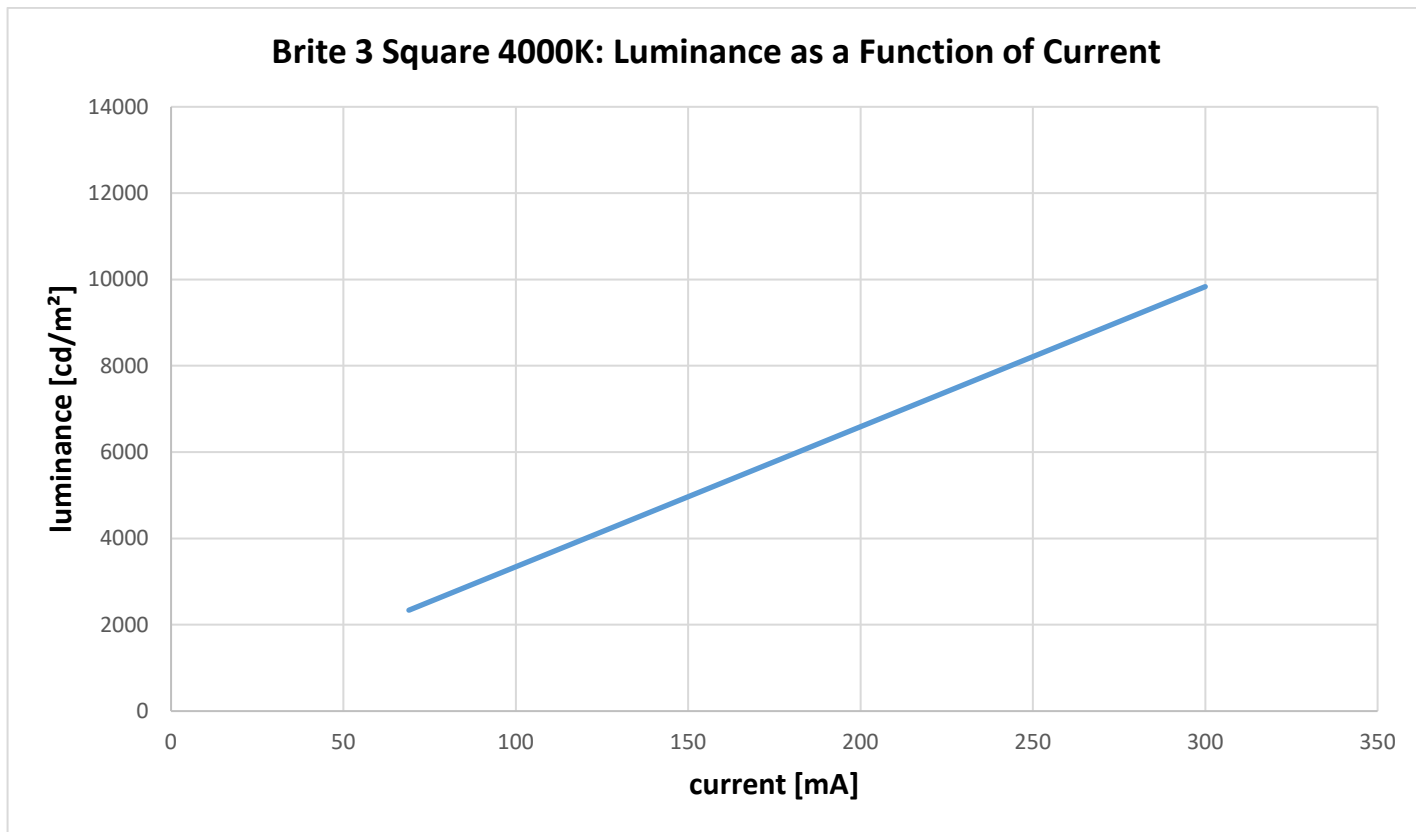
Current – Voltage – Luminance Characteristics

Figure 15: Luminance versus forward current at room temperature, Brite Square 4000K, level 1

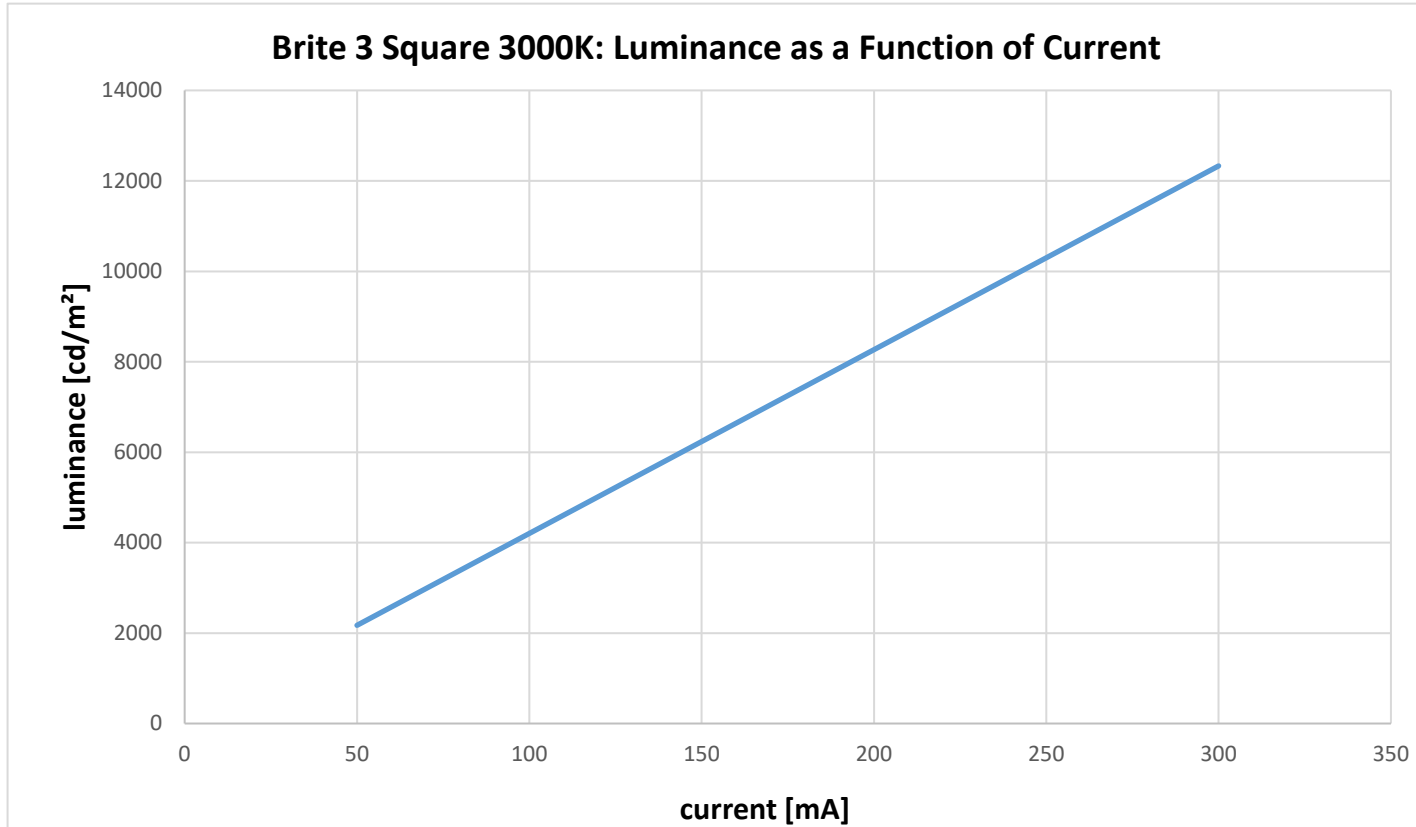


Figure 16: Luminance versus forward current at room temperature, Brite Square 3000K, level 1

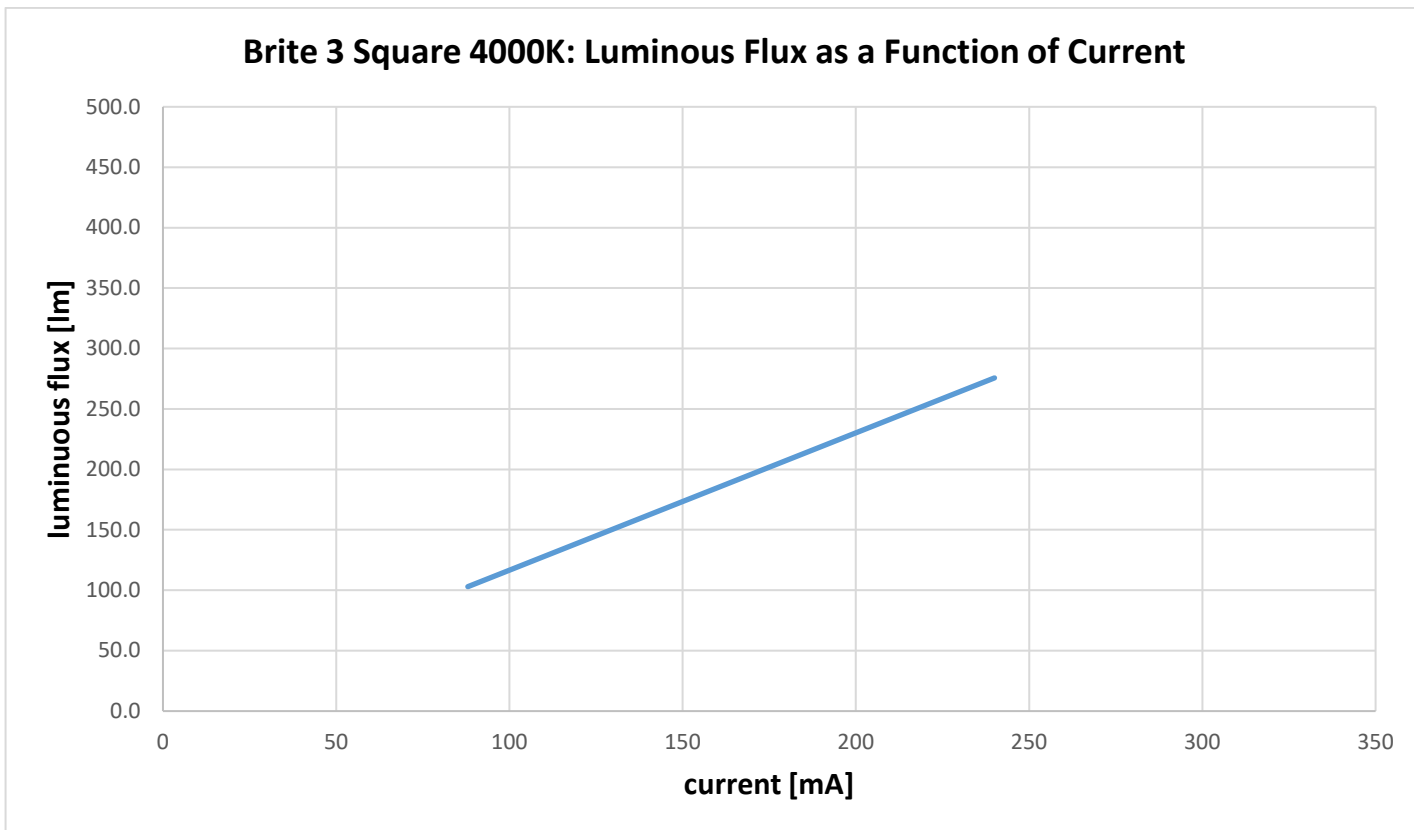


Figure 17: Luminous flux vs current, 4000K, level I

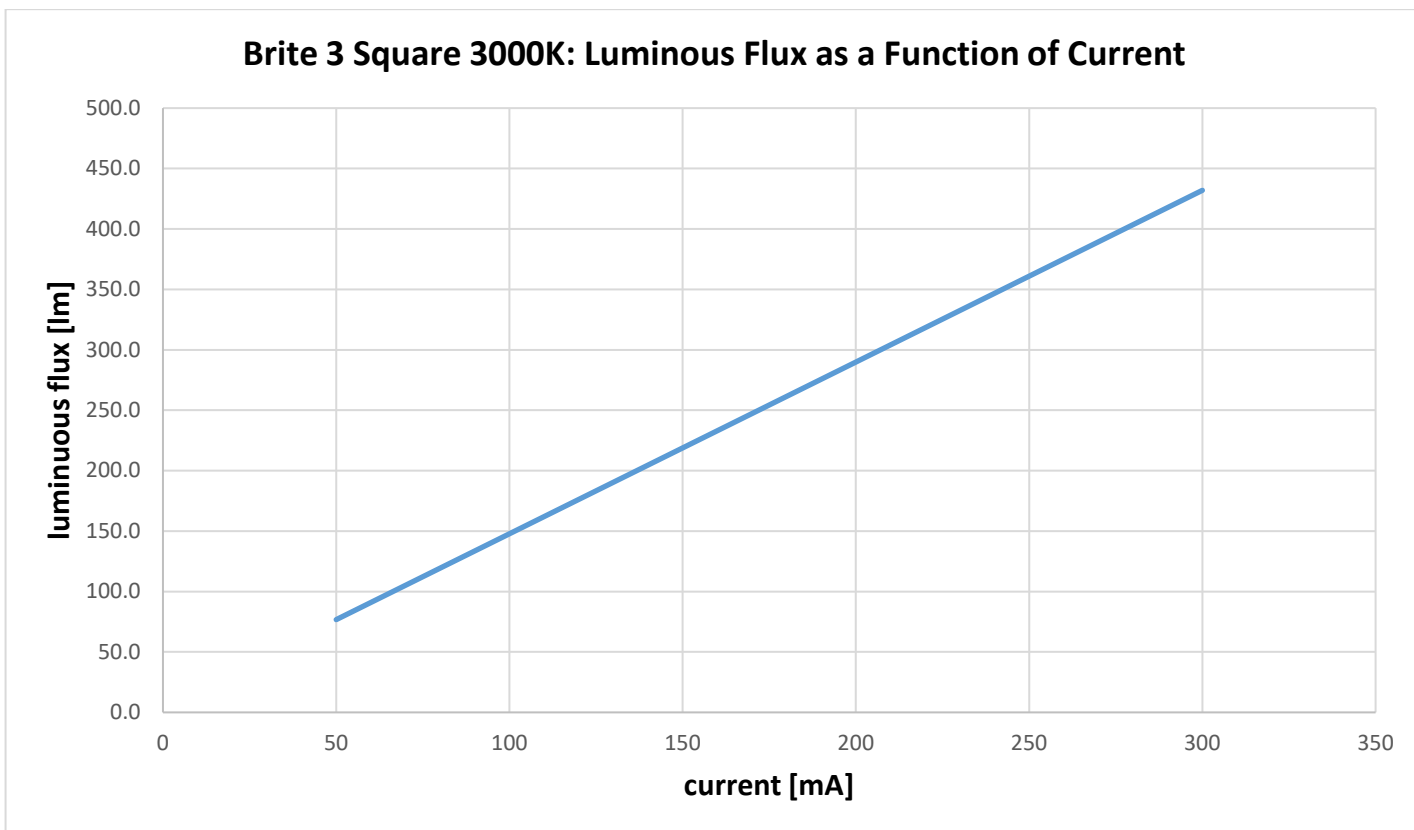


Figure 18: Luminous flux vs current, 3000K, level I

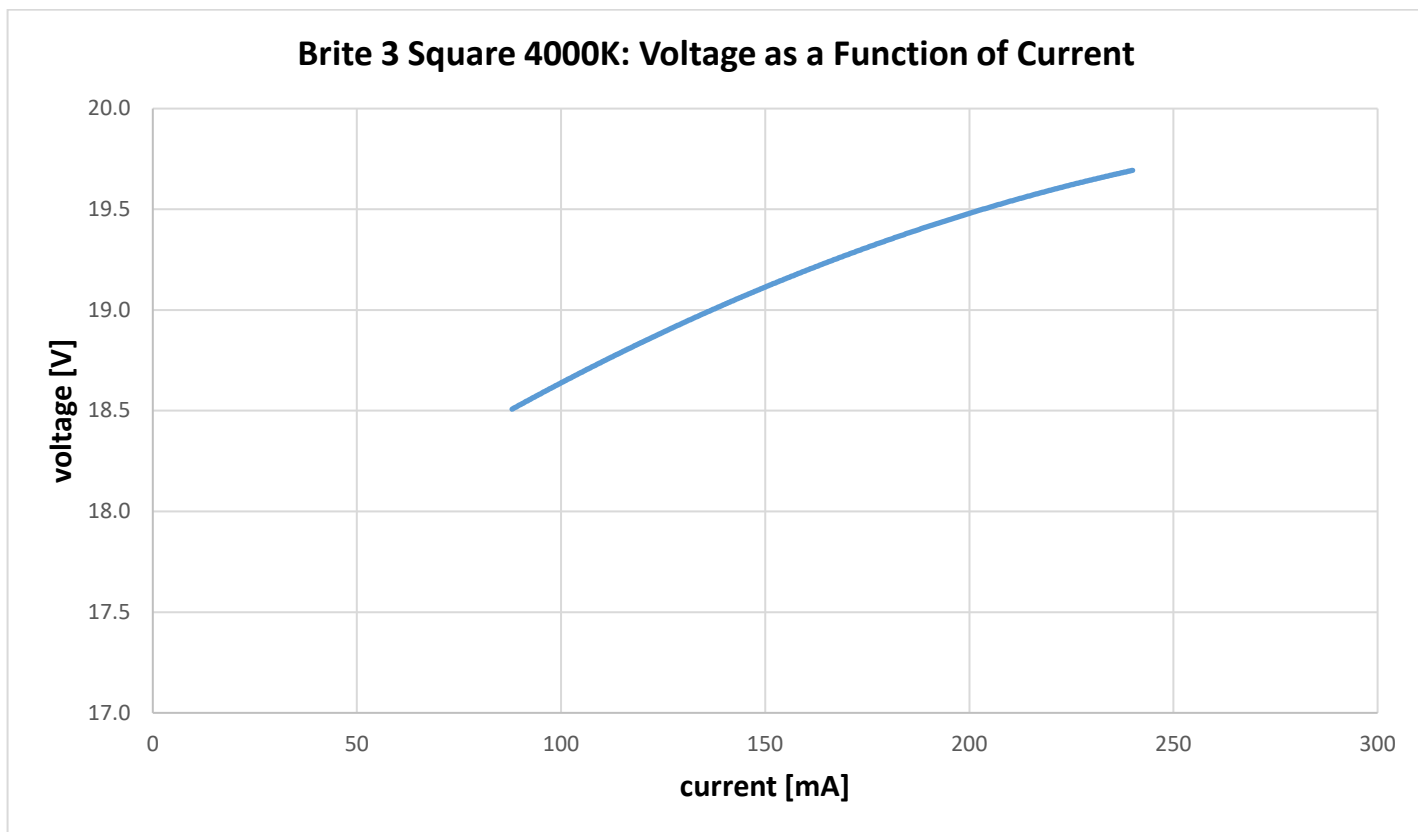


Figure 19: Voltage versus forward current at room temperature, 4000K, level 1

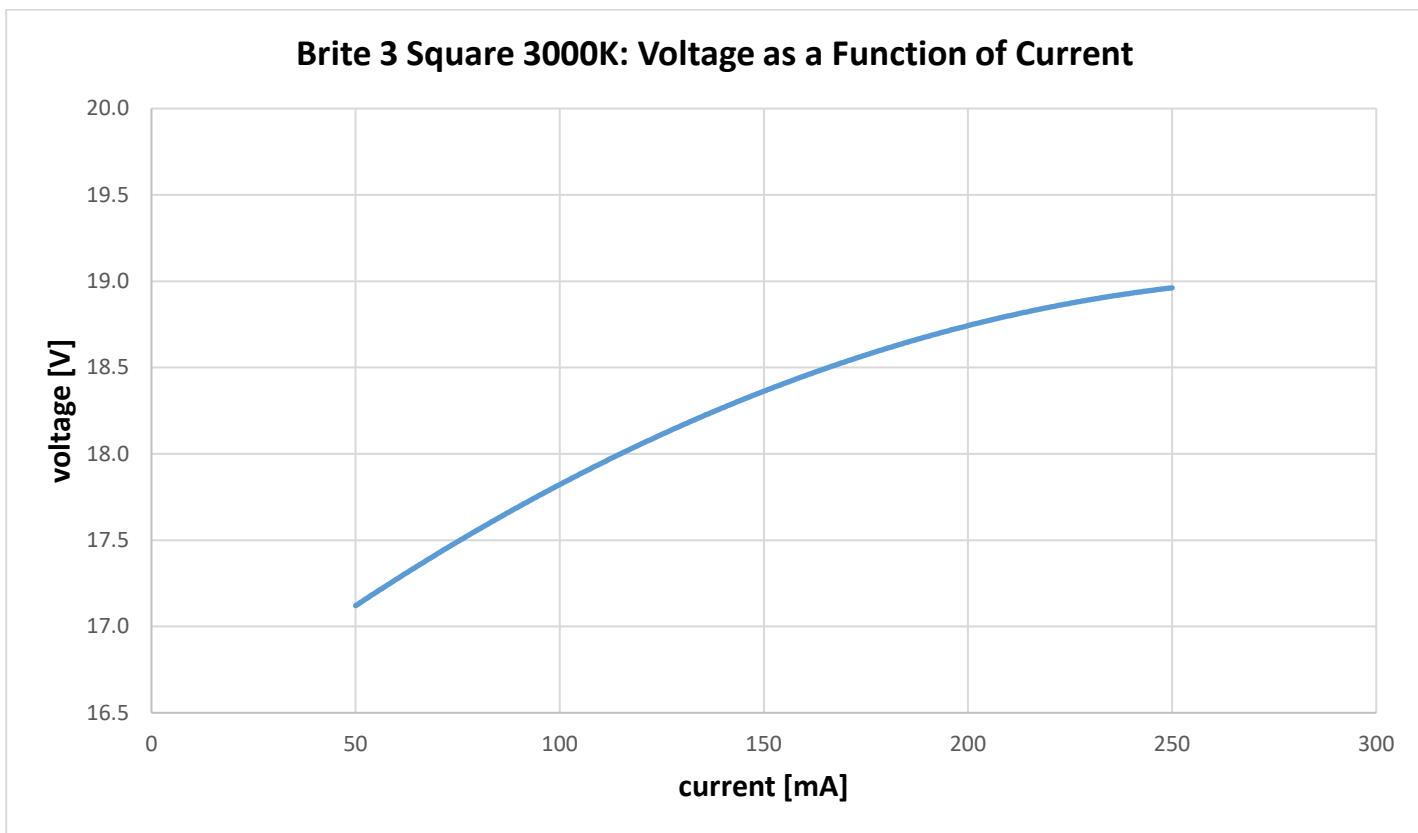


Figure 20: Voltage versus forward current at room temperature, 3000K, level 1

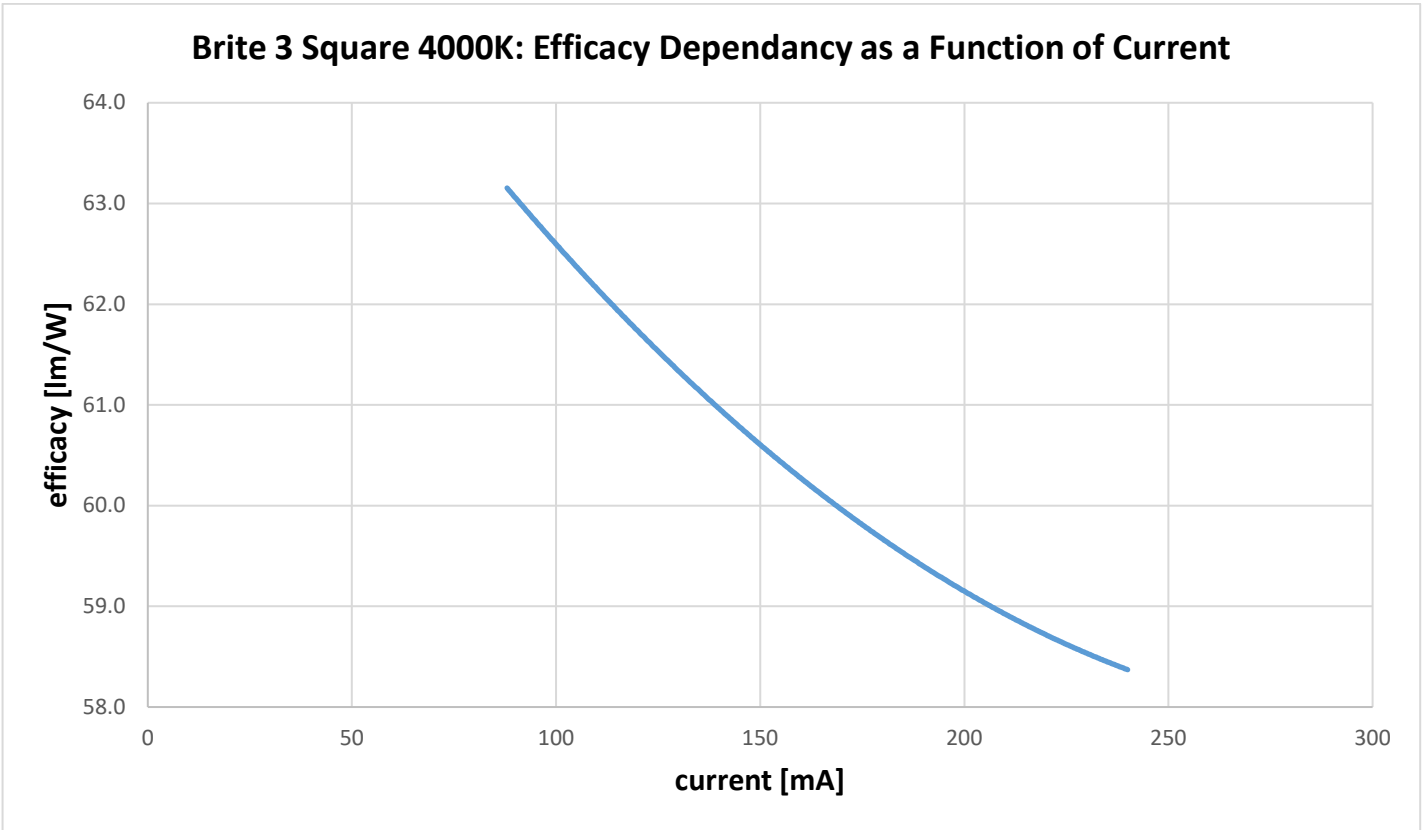


Figure 21: Efficacy versus current at room temperature, 4000K, level I

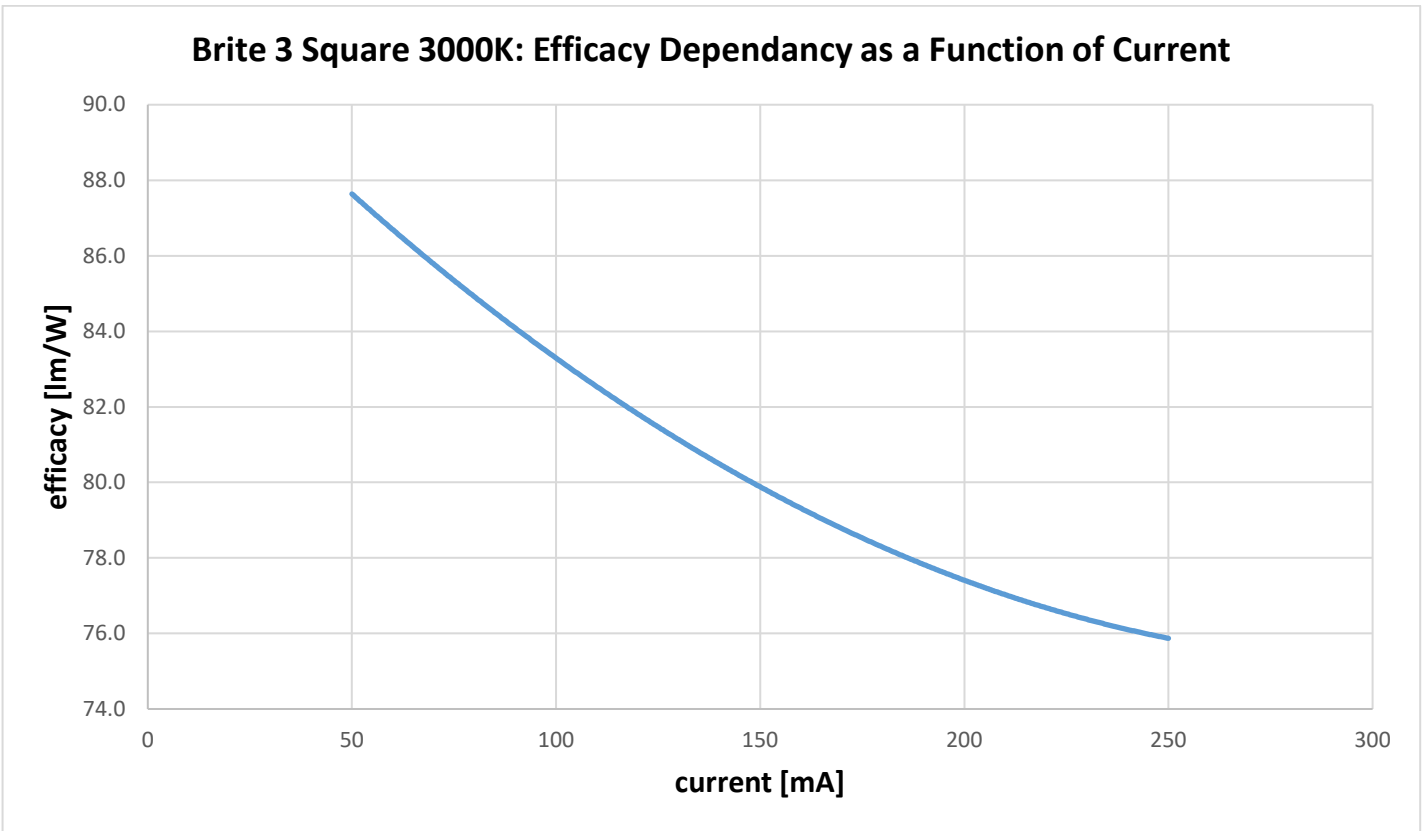


Figure 22: Efficacy versus current at room temperature, 3000K, level I

Homogeneity of Optical Parameters

The OLED Panel Brite 3 Square is a large area device and the luminance value may depend on the location within the active area. A very small color point distribution may also be observed.

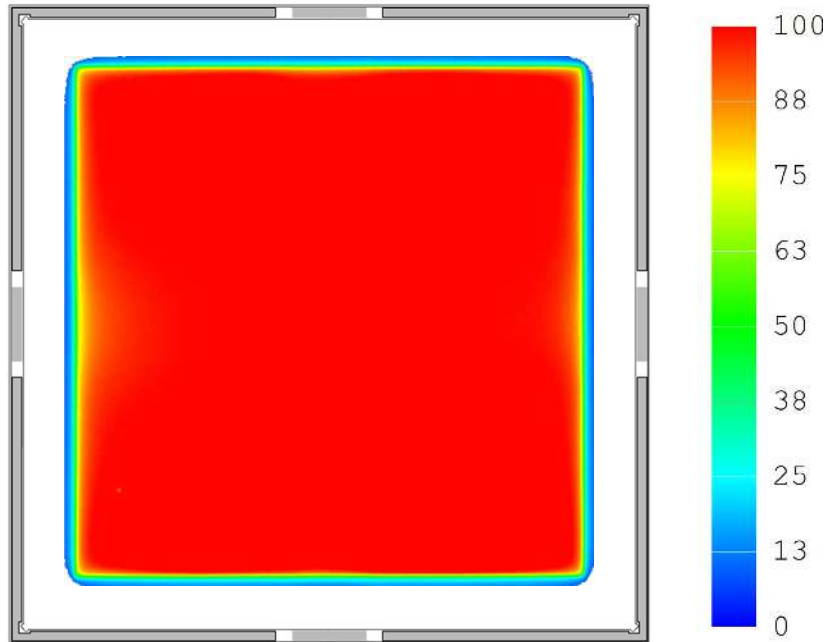


Figure 23: Typical luminance distribution for a Brite 3 Square Level 1. Operation conditions: vertical in air, RT (= 25 °C), $I = I_{in rated}$

Angular Dependency

The luminance (measured in cd/m^2) of the OLED light depends on angle of observation. Figure 24 and 25 show typical values for the OLED Panel Brite 3 Square Level I 4000K and 3000K operated at different driving currents.

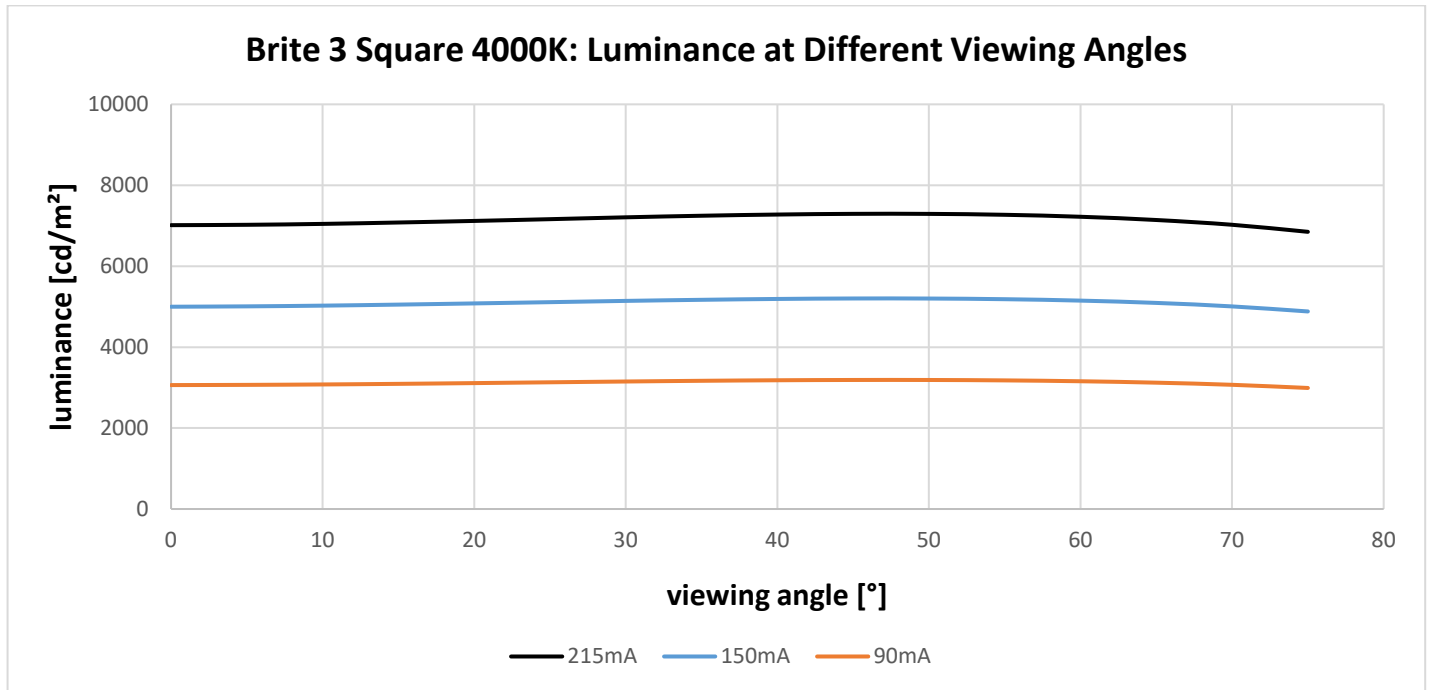


Figure 24: Luminance as function of the viewing angle. Driving currents $I = 0.090 \text{ A}, 0.150 \text{ A}, 0.215 \text{ A}, 4000\text{K}$

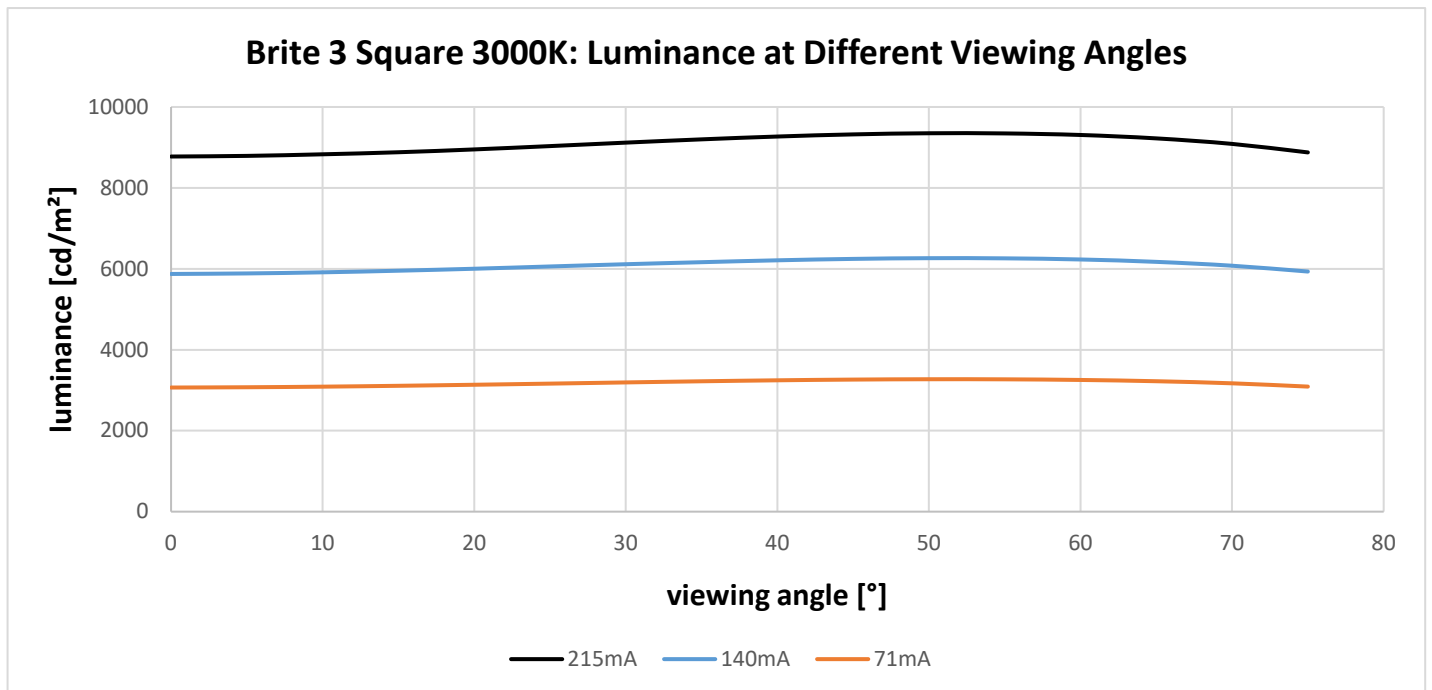


Figure 25: Luminance as function of the viewing angle. Driving currents $I = 0.071 \text{ A}, 0.140 \text{ A}, 0.215 \text{ A}, 3000\text{K}$

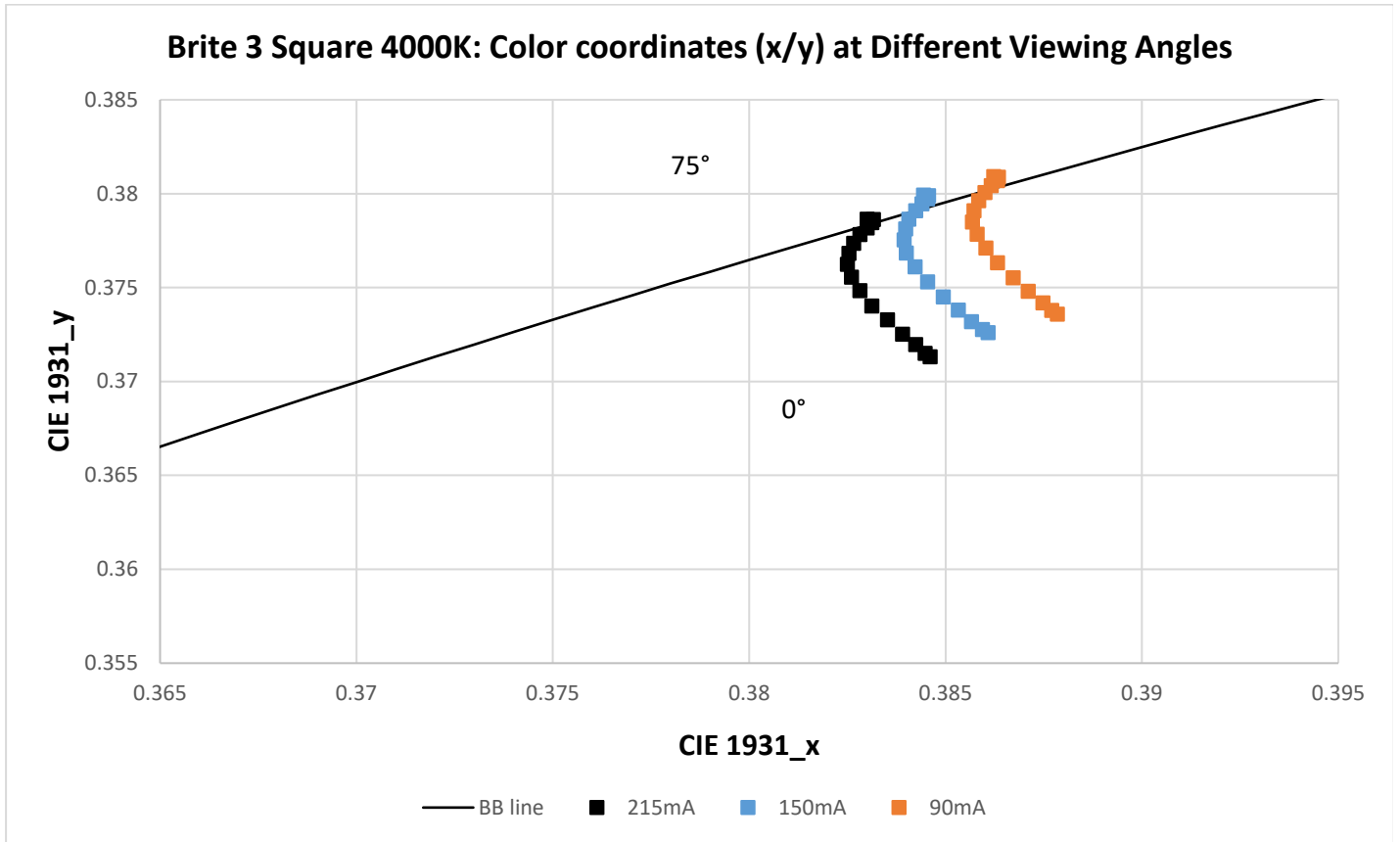


Figure 26: CIE x/y as function of the viewing angle. Driving currents $I = 0.090\text{ A}, 0.150\text{ A}, 0.215\text{ A}$, 4000K, level 1

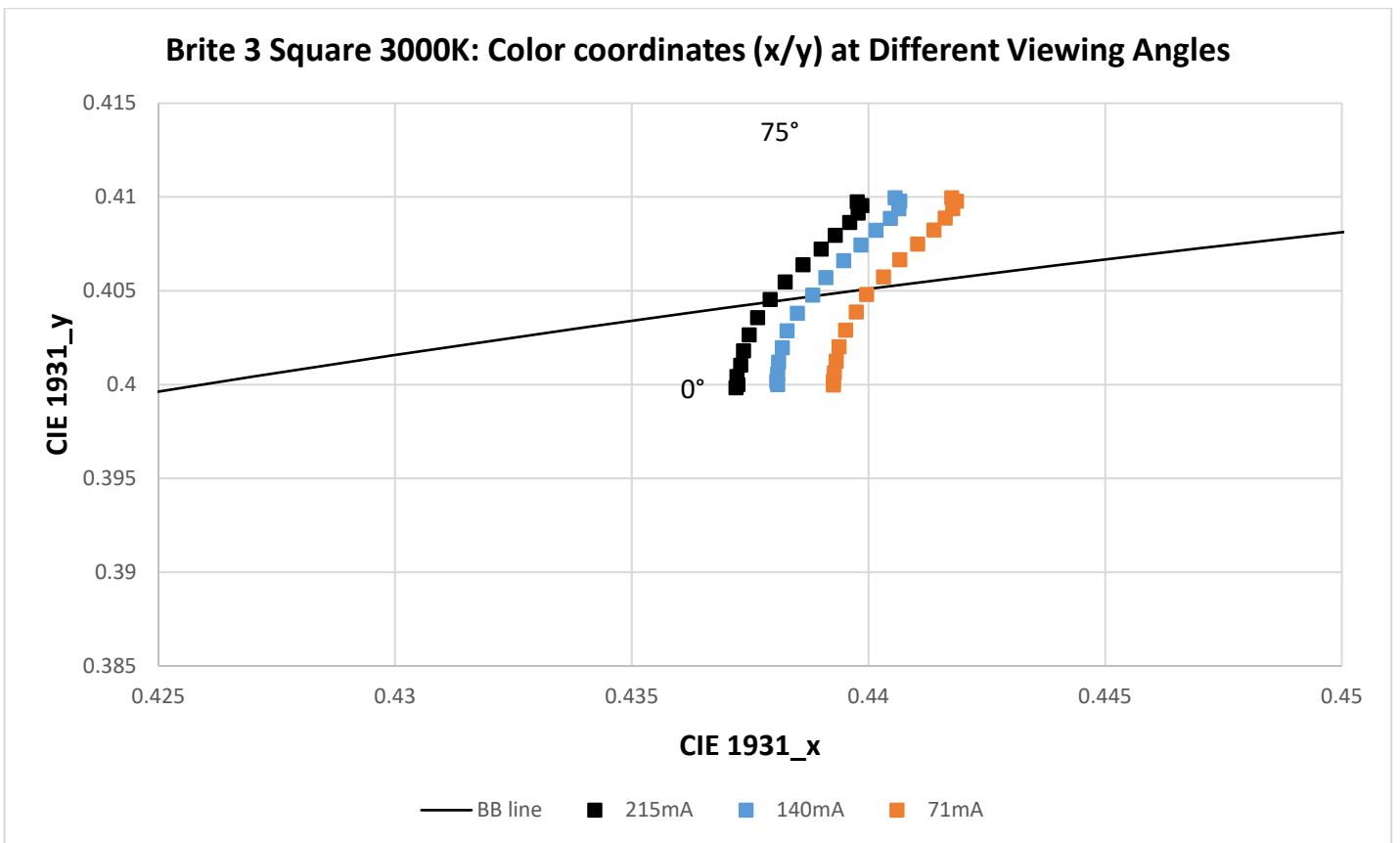


Figure 27: CIE x/y as function of the viewing angle. Driving currents $I = 0.071\text{ A}, 0.140\text{ A}, 0.215$, 3000K, level 1

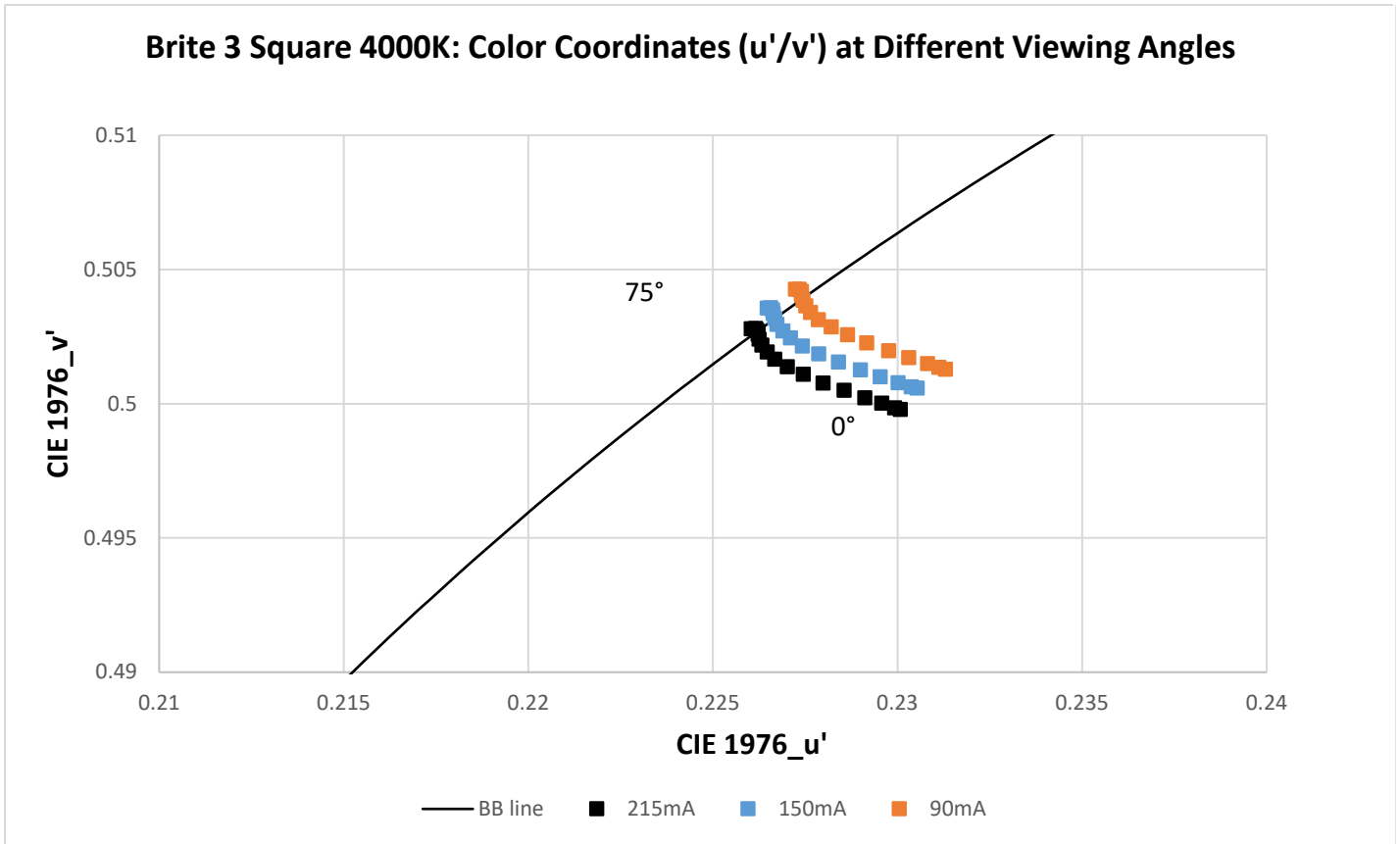


Figure 28: CIE u'/v' as function of the viewing angle. Driving currents $I = 0.090\text{ A}, 0.150\text{ A}, 0.215\text{ A}$, 4000K, level I

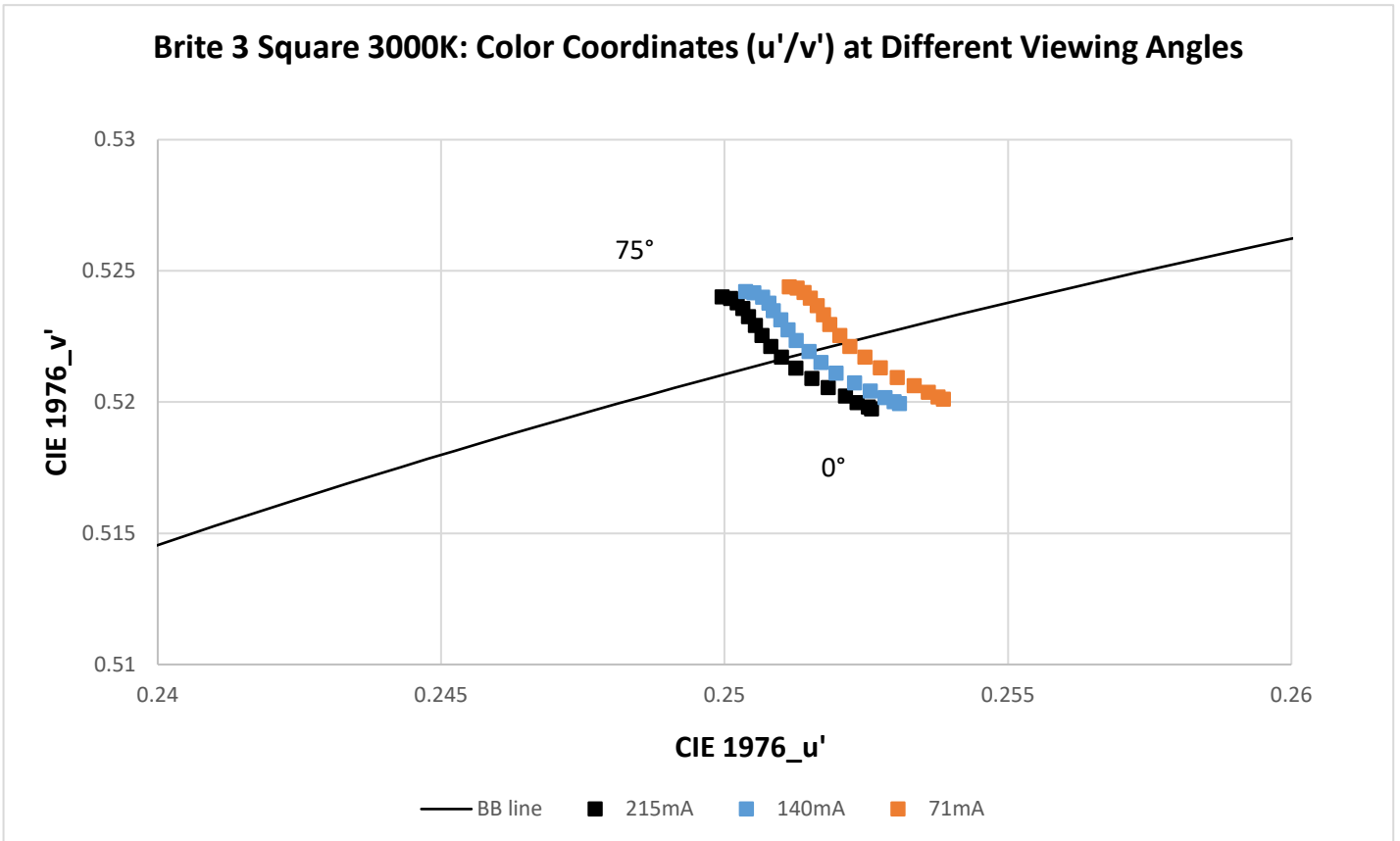


Figure 29: CIE u'/v' as function of the viewing angle. Driving currents $I = 0.071\text{ A}, 0.140\text{ A}, 0.215\text{ A}$, 3000K, level I

THERMAL CHARACTERISTICS

OLEDs can generate a certain amount of heat. Despite the fact that no active cooling is required, the panels should not be covered in order to avoid heat accumulation.

The OLED temperature during operation depends on ambient conditions and driving current. Indicative values for internal (organics) temperature of the device can be measured at the glass surface at the center of the device with a thermocouple attached.

Typical temperature for the Brite 3 Square Level I is 35 °C with the following set-up:

- $I = I_{in\ rated} = 0.215\ A$
- $T_{ambient} = RT = 25\ ^\circ C$
- vertical orientation
- climate chamber, no active convection.

Lifetime

Luminous flux reduces with lifetime of the OLED. The luminous flux of the Brite 3 Square decreases to approximately 70% after 30,000 hours at rated current.

Brite 3 Square 4000K

Specification item	Value	Luminous flux	Condition
OLED Panel Lifetime L70B50	30,000 hours	250lm	@ $I_{in\ rated} = 0.215\ A$, $T_{organic} = 35\ ^\circ C$
OLED Panel Lifetime L70B50	100,000 hours	100lm	@ $0.090\ A$, $T_{organic} = 30\ ^\circ C$

Brite 3 Square 3000K

Specification item	Value	Luminous flux	Condition
OLED Panel Lifetime L70B50	30,000 hours	300lm	@ $I_{in\ rated} = 0.215\ A$, $T_{organic} = 35\ ^\circ C$
OLED Panel Lifetime L70B50	100,000 hours	100lm	@ $0.070\ A$, $T_{organic} = 30\ ^\circ C$

Voltage increases over lifetime of the OLED; color and homogeneity of the panel may also change.

Storage Lifetime

Under the recommended storage conditions the shelf life of the OLED is 2 years

General Handling Recommendations and Care

Cleaning

Please avoid scratching the front side with any hard or sharp objects. OLEDs can be cleaned with any soft textile. If required use a damp cloth but avoid extensive moisture.

Use of a compressed air spray to remove regular dust from the individual panels is advised for everyday cleaning. Should fingerprints or more persistent contamination occur, isopropanol applied to a lint-free cloth can be used to gently clean the surface of the OLED. Clean using circular movements beginning at the center of the OLED and moving outwards towards the edges. Contact with water is to be avoided.

Storage and Operating

Please note that the recommended storage temperature is 15 °C to 25 °C. The recommended relative storage humidity is 65% or lower. Avoid exposing OLEDs to UV light.

Safety

Please be careful when handling OLEDs. The edges of the OLED panels may be sharp and can chip or break.

In the unlikely event that an OLED fails, the temperature may rise locally to high levels. To avoid this the OLED should be turned off immediately.

Disposal

OLED light engines are made of nearly 100% recyclable materials, and are free of mercury and other harmful substances, promoting sustainability.

Please note, OLEDs should be disposed of according to local legislation.

Logistical Data

Specification item	Value
Product name	OLED Panel Brite 3 Square 4000K Level 1
Order code	LPB3300S1NWL101
Pieces per box	20

Specification item	Value
Product name	OLED Panel Brite 3 Square 4000K Level 1.5
Order code	LPB3300S1NWL105
Pieces per box	20

Specification item	Value
Product name	OLED Panel Brite 3 Square 4000K Level 2
Order code	LPB3300S1NWL201
Pieces per box	20

Specification item	Value
Product name	OLED Panel Brite 3 Square 3000K Level 1
Order code	LPB3300S1VWL101
Pieces per box	20

Specification item	Value
Product name	OLED Panel Brite 3 Square 3000K Level 1.5
Order code	LPB3300S1VWL105
Pieces per box	20

Specification item	Value
Product name	OLED Panel Brite 3 Square 3000K Level 2
Order code	LPB3300S1VWL201
Pieces per box	20

Contact:

OLEDWorks

1645 Lyell Avenue, Suite 140
Rochester, NY 14606, USA

Philipsstr. 8
52068 Aachen, Germany

marketing@oledworks.com



© 2020 OLEDWorks
All rights reserved. Correct as of March 2020.